



University of Jordan
Faculty of Engineering and Technology
Department of Chemical Engineering

Chemical Engineering Laboratory (1)

(0915361)

Experiment Number -1-

Losses in Piping System

Objective:

- To find the pressure losses across valves, along pipes and across fittings for a range of flow rates.
- To find K values for fittings and valves from actual experiment.
- To compare theoretical friction factor from the Blasius equation with that found from actual results.

Equipment:

The following equipments is required to perform the Losses in Pipes experiment:

- The H16 Losses in Piping System device.
- H1F Digital Hydraulic Bench.
- H16p Optional Rough Pipe Assembly.



Figure 1: H16 Losses in piping system

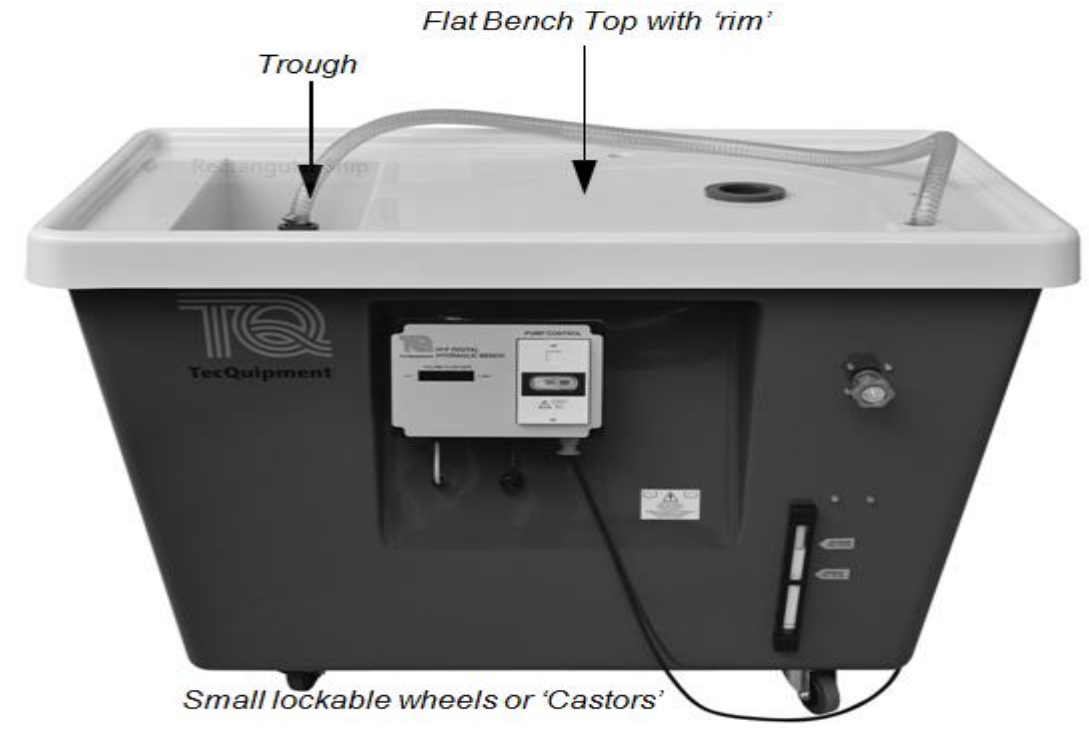

Figure 2: Digital Hydraulic Bench.

Equipment Description:

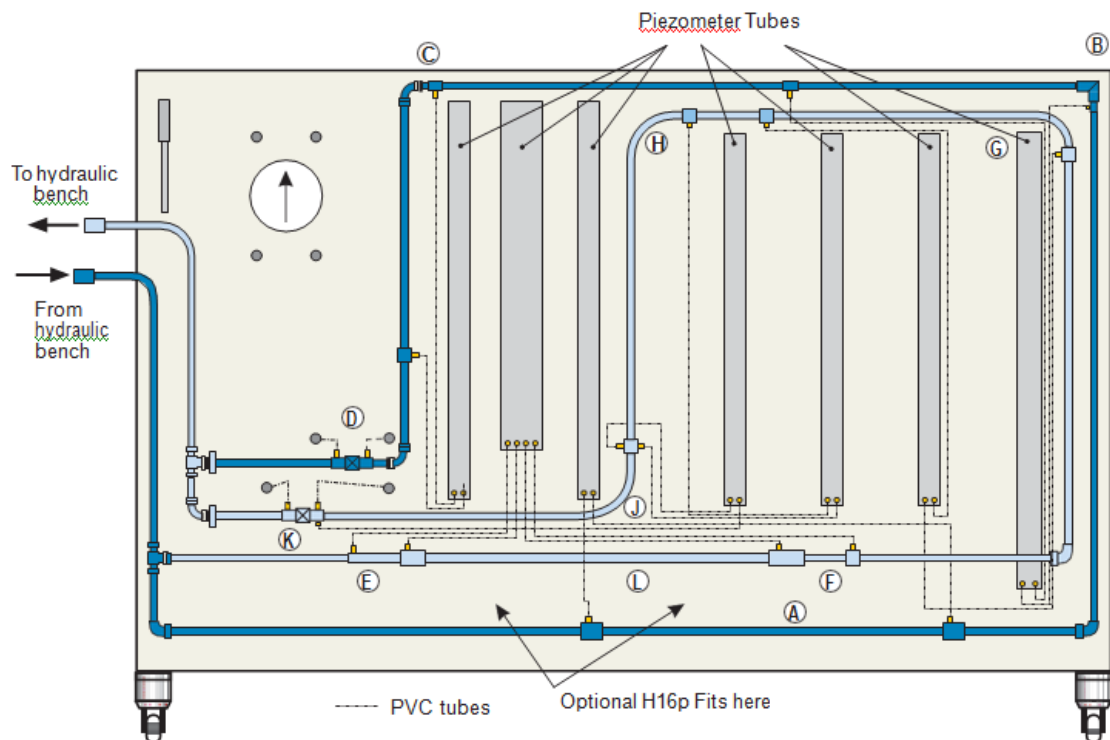

Figure 3: Main parts.

Figure 3 shows a diagram of the main parts. The parts include two separate circuits; one painted dark blue, one painted light blue. Each circuit has a number of pipe system components. Both circuits are supplied with water from the same hydraulic bench. A gate valve controls the flow in the dark blue circuit. A globe valve controls the flow in the light blue circuit. The valves are both downstream of the pipe work to reduce the chance of turbulence from the valves affecting the pipe work readings.

The piezometer tubes measure pressure change across the pipe work components. A differential pressure gauge measures the pressure change across the valves.

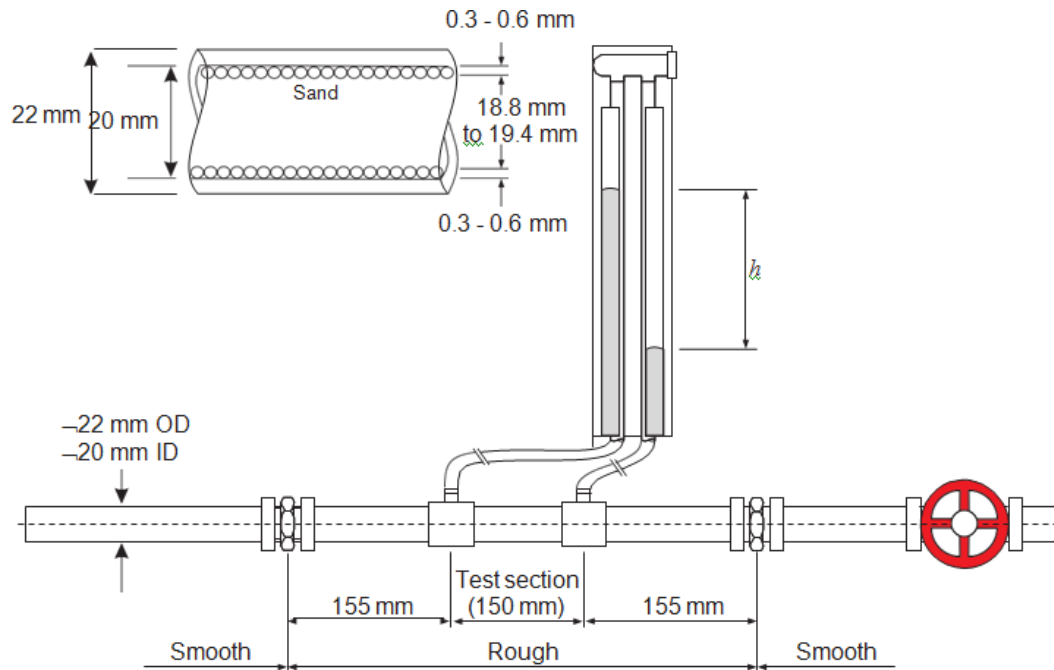

Figure 4: H16p details

The optional H16p fitted to the main unit of the H16. It works as a stand-alone unit because it has its own piezometer. It only needs connection to a hydraulic bench for water supply and flow measurement.

The main part of this optional assembly is a length of pipe that includes a short section of roughened pipe, two pressure tappings and a downstream flow control valve. The roughened section of pipe has an artificially roughened internal surface. The pressure tapping's measure the pressure drop along a test section of the roughened pipe, to avoid any minor disturbance at the entrance and exit to the roughened section. The flow control valve is downstream so that it cannot introduce turbulence to the flow, affecting results.

Technical Details:

Pipes: Standard-bore straight pipe (nominally 13.6 mm bore copper)

Larger-bore straight pipe (nominally 26.2 mm bore copper)

Bends: 90-degree miter bend (no radius) $R/d=0$

Elbow (13.6 mm radius) $R/d=1$

Small radius, smooth 90° bend (50 mm radius) $R/d=3.7$

Medium radius, smooth 90° bend (100 mm radius) $R/d=7.35$

Large radius, smooth 90° bend (150 mm radius) $R/d=11.03$

Tapping Distance: Distance L between pressure tapping for pipe and bends = 0.914m

Theory:

For an incompressible fluid (for example water) flowing through a pipe, the following equations apply:

$$Q = V_1A_1 = V_2A_2 \text{ (Continuity equation)}$$

$$Z_1 + \frac{P_1}{\rho g} + \frac{V_1^2}{2g} = Z_2 + \frac{P_2}{\rho g} + \frac{V_2^2}{2g} + h_L \text{ (Bernoulli's equation)}$$

The continuity equation shows that the volume flow at one part of the pipe is the same as the volume flow at any other part (assuming no leaks or flow diversions)

Bernoulli's equation shows that when calculating relative properties of flow along a pipe, you must allow for the change in head (or head loss).

Total head loss is the relative pressure drop (measured in meters of water) caused by the flow resistance of a pipe system. There are two main causes of total head loss (h_L) in a pipe system:

1. Head loss (h_F) due to pipe friction throughout the circuit (**Major losses**).
2. Head loss due to localized effects such as valves, sudden changes in area and bends. These are often termed the **minor head losses**, as they are usually small compared to the frictional head losses of the pipe work.

So generally, around any fitting: $h_L = h_F + \text{minor losses}$

Mutual interference between parts that are near each other in a complex circuit means that total head loss may not be simply the sum of the individual losses of each part.

To help predict the relative head loss in fittings and valves caused by changes in dimensions, engineers use a term called the **K** value. This is a **loss coefficient** or **loss factor** based on the dimensions of the fitting. For a sudden contraction or expansion it is based on the area ratio. For a bend, it is based on the bend radius and pipe diameter.

Note that the **K** value is only reliable when predicting flow at high Reynolds number. It is not reliable when experimenting with laminar flow.

$$K = \frac{h_L}{V^2/2g} \quad \dots \dots \dots (1)$$

Equation 1 gives the standard relationship loss coefficient and head loss for a fitting at a given flow velocity.

A French engineer, Henry Darcy experimented with fluid flow through pipes **in turbulent conditions**, proving a relatively accurate equation that is commonly named after him. It quantifies the frictional losses and helps predict a reasonably accurate value for the head loss due to friction along the pipe, based on actual results:

$$h_f = \frac{f \cdot L \cdot V^2}{2dg} \quad \dots \dots \dots (2)$$

Where f is the Friction factor and it is a dimensional value.

But only for flows with Reynolds numbers of less than 2100 (**generally laminar flow**):

$$f = \frac{64}{Re} \quad \dots \dots \dots (3)$$

A German physicist (Paul Blasius) created an alternative equation, that works for Reynolds numbers greater than 4000 (turbulent flow) **in smooth pipes**.

$$f = \frac{0.316}{Re^{0.25}} \quad \dots \dots \dots (4)$$

For both the contraction and enlargement, it is important to know that the total head loss is the sum of the measured head loss across the fitting and the loss due to the change in velocity head

$$h_L = \text{measured value} + \frac{V_1^2 - V_2^2}{2g} \quad \dots \dots (5)$$

To calculate the head loss due to the bends (h_B), you must allow for the additional loss caused by the pipe work that the bend is made from and which creates the entrance and exit to the bend as shown below:

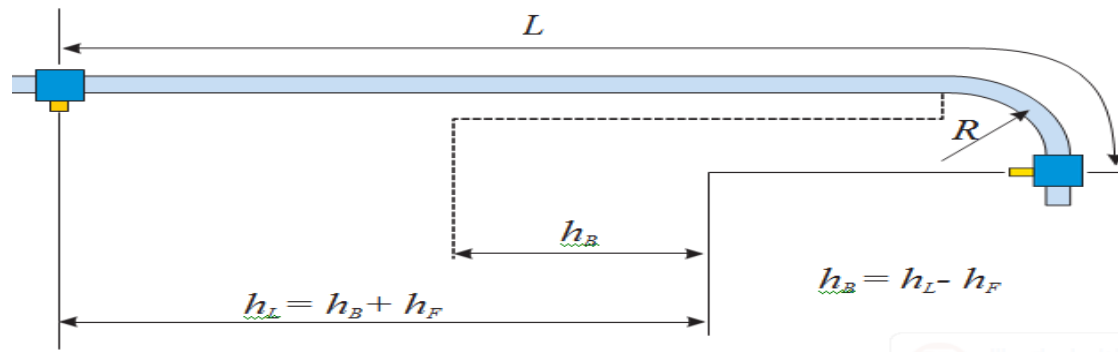

Figure 5: Losses in bends and their pipe work.

Rough and Smooth pipes:

Blasius's work defined two types of pipe friction for turbulent flow:

Smooth turbulent pipe friction - where fluid viscosity becomes the most important factor and f is virtually proportional to Reynolds number Re .

Rough turbulent pipe friction - where both viscosity and pipe wall roughness are the most important factors.

A German engineer Johann Nickuradse also experimented with pipe flow during the first half of the twentieth Century. He added small grains of sand to the inner wall of pipes, so that he could produce a measurable relative roughness (k/D), and then tested the pipes to find how the roughness affected flow.

For example, for a roughness height k of 0.6 mm in a pipe of internal diameter 18 mm, the relative roughness $k/D = 0.6/18 = 0.033$.

The H16p has a pipe internal diameter of 20 mm and the sand grains give a roughness of between 0.3 and 0.6 mm, giving a k/D of between $0.3/20 = 0.015$ and $0.6/20 = 0.03$. This gives an average relative roughness of around 0.0225.

Figure 6 shows typical results of Nickuradse tests for pipes of between 0.001 and 0.033 relative roughness.

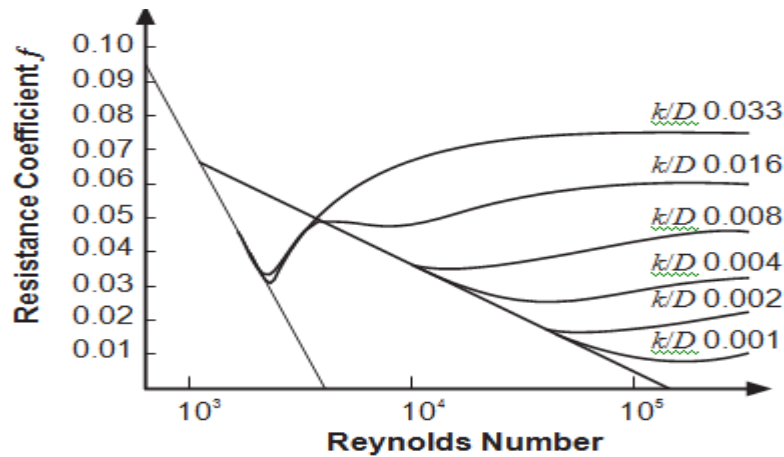

Figure 6 : Nickuradse Curves.

Procedures:

Procedure 1 – Dark Blue Circuit and Gate valve:

- Connect the hydraulic bench supply to the inlet pipe of the H16. Directing the outlet of the H16 into the hydraulic bench tank for flow measurement.
- Start your hydraulic bench and adjust for full flow. Fully shut the globe valve and fully open the gate valve.
- Measure and record the water temperature for reference.
- Make sure to remove all trapped air in the piezometer tubes before start taking readings by gently taps them with your finger.
- Slowly shut the gate valve until the pressure drop across it reaches 0.1 bar.
- Wait for conditions to stabilize, making a small adjustment of flow at the hydraulic bench or the valve if necessary.
- Record the flow rate using the hydraulic bench.
- Record the pressure drop across each piezometer (in mm of water) around the circuit.
- Slowly shut the valve until the pressured drop across it reaches 0.2 bar and repeat.
- Repeat in steps of 0.05 bar to the maximum you can achieve from your hydraulic bench (usually around 0.45 to 0.5 bar).

Procedure 2 – Light Blue Circuit and Globe valve:

- Connect the hydraulic bench supply to the inlet pipe of the H16. Directing the outlet of the H16 into the hydraulic bench tank for flow measurement.
- Start your hydraulic bench and adjust for full flow. Fully shut the gate valve and fully open the globe valve.
- Measure and record the water temperature for reference.

- Make sure to remove all trapped air in the piezometer tubes before start taking readings by gently taps them with your finger.
- Slowly shut the gate valve until the pressure drop across it reaches 0.1 bar.
- Wait for conditions to stabilize, making a small adjustment of flow at the hydraulic bench or the valve if necessary.
- Record the flow rate using the hydraulic bench.
- Record the pressure drop across each piezometer (in mm of water) around the circuit.
- Slowly shut the valve until the pressured drop across it reaches 0.2 bar and repeat.
- Repeat in steps of 0.05 bar to the maximum you can achieve from your hydraulic bench (usually around 0.45 to 0.5 bar).

Calculations:

For Dark Blue Circuit – Straight pipe:

For each flow rate:

- Convert piezometer 3-4 or 8-9 results into meters of water. Ignore any results that produce piezometer differences of less than 20 mm (0.02 m), as readings errors increase at these points and produce unwanted scatter in your results.
- Calculate the flow velocity.
- Find the Reynolds number.
- Calculate the friction factor from actual dimensions using equation 2 and from simpler Blasius equation.
- Calculate the log of the head loss and the volume flow rate , then produce a chart of log head loss against log volume flow and find the gradient n.
How does it compare with theory??
- Create a chart of friction factor (vertical axis) against Reynolds number. Add your actual and Blasius results for comparison and comment on the differences.

For Light Blue Circuit – Bends:

For each flow rate:

- Convert piezometers readings for the five bends (including the mitre and elbow) into meters of water. Ignore any results that produce piezometer differences of less than 20 mm (0.02 m), as readings errors increase at these points and produce unwanted scatter in your results.
- Calculate the flow velocity.
- Find the Reynolds number.
- Calculate $V^2/2g$.
- Calculate the friction factor from the Blasius equation.
- Calculate the loss due to the pipe work h_F .

1. Create a blank table of results, similar to the above.
2. Fully open the H16p valve and the hydraulic bench valve.
3. Start the pump of the hydraulic bench and allow water to pass around the circuit for several minutes to remove any trapped air.
4. Measure your water temperature.
5. Use the hydraulic bench to measure the flow rate.
6. Record the pressure drop along the roughened test section.
7. Use the H16p control valve to reduce the flow from maximum to minimum in at least six equal steps.
8. At each step, wait for the pressure readings to stabilize, then record the flow and pressure drop.

Calculations - Roughened Pipe:

- Find the kinematic viscosity of the water.
- For each flow rate, calculate the velocity based on a 19 mm diameter.
- Calculate Reynolds number Re and then use actual results to find friction factor f .
- Add your results to the Moody Chart and compare with those of Moody and Nickuradse.

References:

1. Gean Koplis, "Transport Processes Momentum, Heat and Mass", Augn and Bacon, 1983.
2. J.M. Coulson and FF Richardson," Chemical Engineering" Vol.1, Third Edition, 1980, pergamon prss.

Losses in Pipes Experiment Data Sheet

Dark Blue Circuit and Gate Valve:

Pressure Gauge (bar)	Pressure Gauge (m water)	Flow rate (L/s) (volumetric) or kg/s (gravimetric)	Volume Flow rate ($\text{m}^3 \cdot \text{s}^{-1}$)	Dark Blue circuit piezometer tube heights (mm water)		
				1-2	3-4	5-6
0.1						
0.15						
0.2						
0.25						
0.3						
0.35						
0.4						
0.45						
0.5						

Water Temperature:

	Pressure Gauge (m water)	Flow rate (L/s) (volumetric) or kg/s (gravimetric)	Volume Flow rate ($\text{m}^3 \cdot \text{s}^{-1}$)	Light Blue circuit piezometer tube heights (mm water)					
				7-8	8-9	9-10	11-12	13-14	15-16
0.1									
0.15									
0.2									
0.25									
0.3									
0.35									
0.4									
0.45									
0.5									

Water Temperature:

Light Blue Circuit and Globe Valve:

Instructor signature and Date:

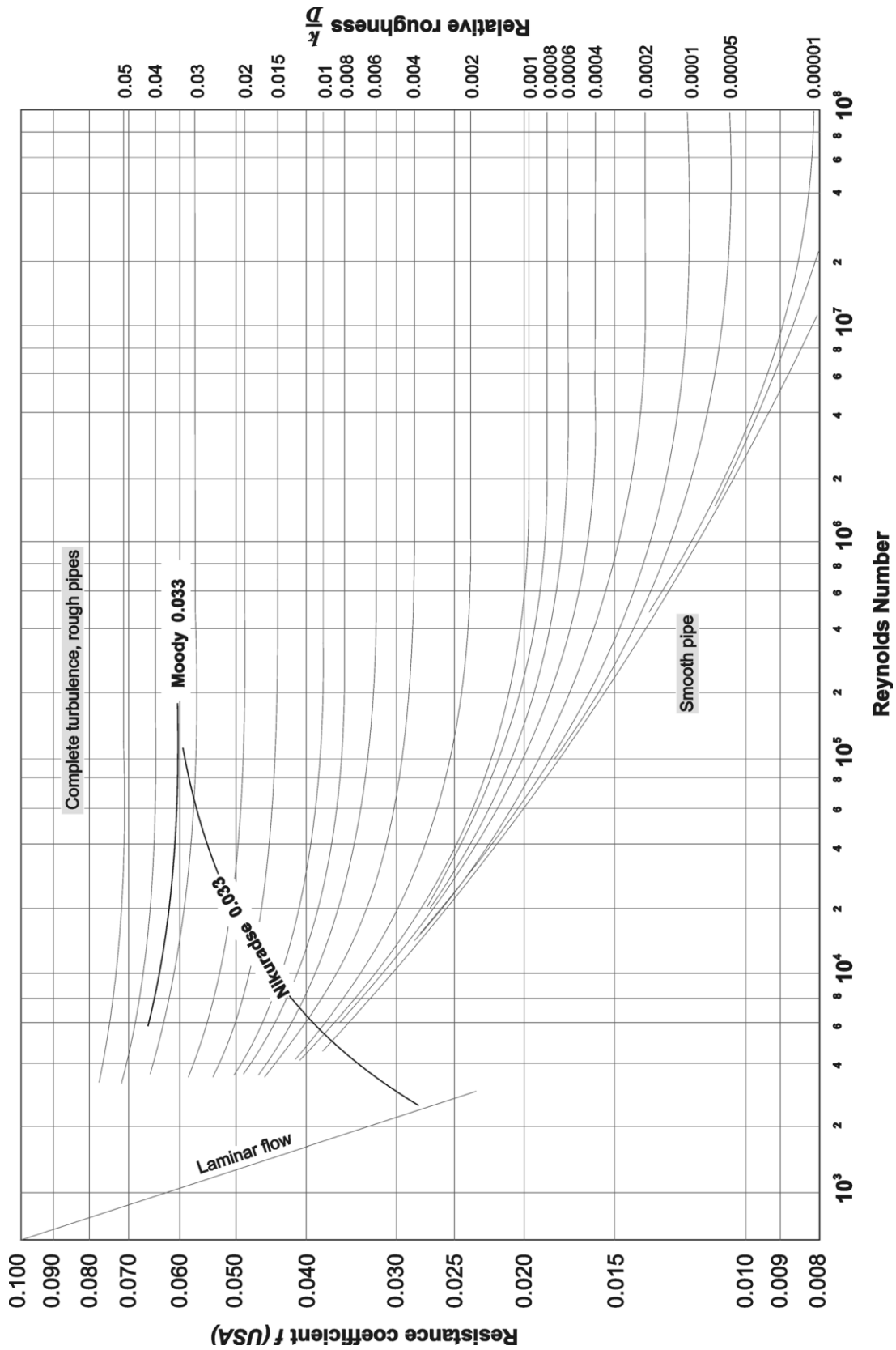

Moody Chart including Nikuradse Results

Experiment Number -2-

Positive Displacement Pumps Characteristics

Objective

To demonstrate how pumps work and show the performance of a selection of positive displacement pumps at constant and variable speeds.

Apparatus

The apparatus consists of the Positive Displacement Pump Module, the Universal Dynamometer, an optional pump (a Vane pump is used here) and TecQuipment's Versatile Data Acquisition System (VDAS). Figure (1) shows the apparatus with its main parts.

The Positive Displacement Pump Module uses oil as the working fluid. The Universal Dynamometer turns the pump which in turn forces the oil around a circuit. The oil comes from an oil reservoir, through an inlet valve and through the pump. It then passes through a pressure relief valve and a delivery valve. It then passes through a gear-type flowmeter and back to the oil reservoir.

Electronic pressure transducers in the circuit measure the oil pressures at the inlet to the pump and at the outlet. A thermocouple measures the oil temperature and a flowmeter measures the oil flow in the circuit.

The transducers, the thermocouple and the flowmeter all connect to a digital display that shows the pressures, temperature and flow.

The TecQuipment's Versatile Data Acquisition System (VDAS) will display, store, chart and export all the important readings from the tests.

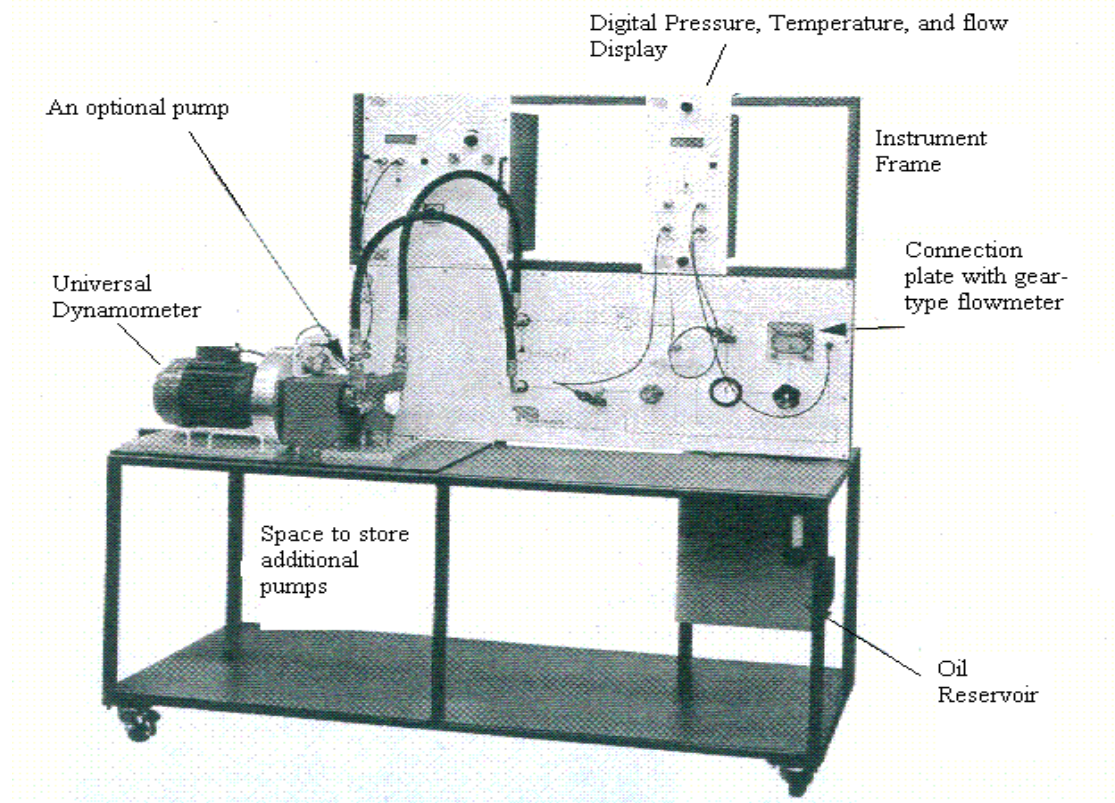

Figure (20): The Positive Displacement Pump Module with its main parts.

Theory

The pressure increase (or head) and flow rate caused by a pump are its two most important qualities. Next most important are its efficiency and power needs. Different types of pumps are designed to process fluids under variable engineering condition.

The pressure increase is simply the difference between the pressures before and after the pump. The flow rate is the amount of fluid that passes through the pump.

Mechanical power (into pump):

This is simply the shaft power at the pump (W_D).

Hydraulic power (from the pump):

The hydraulic power that the pump adds to the fluid is a product of the flow through the pump and the increase in pressure it gives.

$$W_P \text{ (kW)} = (p_2 - p_1) * Q_v \quad \dots\dots\dots (1)$$

Where:

$(p_2 - p_1)$: Delivery pressure-suction pressure (Pa).

Q_v : Volumetric flow rate (m^3/s).

Overall pump efficiency:

$$\eta_p = (W_P / W_D) * 100 \dots\dots\dots (2)$$

Volumetric efficiency:

Volumetric efficiency = (Actual volumetric flow rate/Expected volumetric flow rate)* 100

$$\eta_v = [Q_v / (V_s * N_p)] * 100 \dots\dots\dots (3)$$

Where:

V_s : Swept volume (cm³/rev).

N_p : Speed of the pump (rev/min).

Procedure

1. Turn the “Positive Displacement Pump Module” on.
2. To start the software, double click the “TecQuipment VDAS” icon on the desktop. Then click the “connection” button to connect the software to the device.
3. In the” Pump Information” section, fill the pump type and (cc/rev) depending on the type of pump connected to the module.
4. The experiment consists of three parts, follow the instructions illustrated in each part carefully. **And before you start always do the following:**
 - a. Fully open the inlet and delivery valves.
 - b. Use the button on the pressure display to zero all pressure readings.
 - c. Zero the torque reading of the MFP100 Universal Dynamometer.

Part 1: The Effect of Delivery Pressure at Constant Speed.**Aim:**

To find how the pump performs for a range of delivery pressures (varied load) at a constant speed.

Procedure

1. Press the start button of the Motor Drive and run the speed to 1600rpm (+/- 5 rpm) for at least five minutes and monitor the oil temperature until it stabilizes. Check that any air bubbles have moved away from the flow meter.
2. Slowly shut the delivery valve and maintain the speed until the delivery pressure reaches 2 bar. Allow a few seconds for conditions to stabilize. Click on the record data values button, to record all data automatically (use 15 seconds time intervals).
3. Continue increasing the delivery pressure in 1 bar steps (while keeping the speed constant) to a maximum of 15 bar. At each step. Allow a few seconds for conditions to stabilize.
4. Take a print out of the results that contains speed, shaft power, swept volume, inlet and outlet pressures and flow rate readings.

5. At the end of test, fully open the delivery valve and slowly decrease the speed to zero before you stop the motor.
6. Repeat the test at two other lower speeds. 1200 rpm and 800 rpm are recommended.

Results Analysis:

At each speed:

1. Find the pressure differences across the pump and calculate the hydraulic power.
2. Calculate the expected flow for the speed of your test and the overall and volumetric efficiencies.
3. Plot curves of (flow rate, shaft power, volumetric and overall efficiencies) against pressure difference and discuss your results.
4. Compare the results at different speeds.

Part 2: The Effect of Speed at Constant Delivery Pressure.

Aim:

To find how the pump performs for a range of speeds at a constant delivery pressure (load).

Procedure:

1. Press the start button of the Motor Drive and run the speed to 1600 rpm (+/- 5 rpm) and run the pump for at least five minutes and monitor the oil temperature until it stabilizes.
2. Wait for any trapped air bubbles to move away from the flowmeter before you continue.
3. Slowly shut the delivery valve and maintain the speed until the delivery pressure reaches 15 bar.
4. Allow a few seconds for conditions to stabilize, then click on the record data values button, to record all data automatically (use 15 seconds time intervals).
5. Reduce the speed by 100 rpm steps while adjusting the delivery pressure to keep it constant at 15 bar until you reach 800 rpm. At each step, allow a few seconds for conditions to stabilize.
6. Take a print out of the results that contains speed, shaft power, swept volume, inlet and outlet pressures and flow rate readings.
7. At the end of test, fully open the delivery valve and slowly decrease the speed to zero before you stop the motor.
8. Repeat the test at two other lower fixed delivery pressures. 5 and 10 bar values are recommended.

Results Analysis:

At each delivery pressure:

1. Find the pressure differences across the pump and calculate the hydraulic power.
2. Calculate the expected flow for each speed and the overall and volumetric efficiencies.
3. Plot curves of (flow rate, shaft power, volumetric and overall efficiencies) against pump speed and discuss your results.
4. Compare the results at different delivery pressures.

Results Analysis:

1. Find the pressure differences across the pump and calculate the hydraulic power.
2. Calculate the expected flow for the speed of your test and the overall and volumetric efficiencies.
3. Plot curves of (flow rate, shaft power, volumetric and overall efficiencies) against the inlet pressure.

References:

1. F.A. Holland, "Fluid Flow for Chemical Engineers ", Arnold, 1980.
2. J.M. Coulson and FF Richardson," Chemical Engineering" Vol.1, Third Edition, 1980, Pergamon Press.

Experiment Number -3-

Comparative Fluid Flow Measurement

Objective:

1. Determination of the discharge coefficient (C_d) of an orifice meter and a venturi meter at different Reynolds numbers (Re).
2. Comparison of pressure drops across the orifice meter and the venturi meter.
3. To construct a calibration curve for the rotameter.

Equipment:

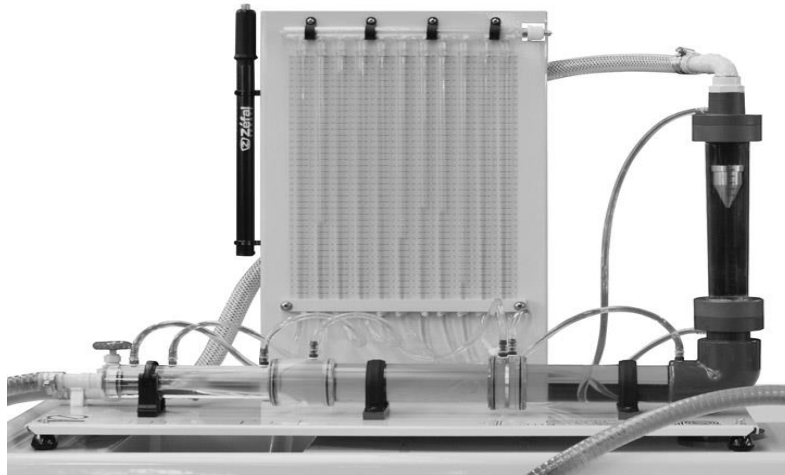

Figure (21): Flow Measurement Methods equipment.

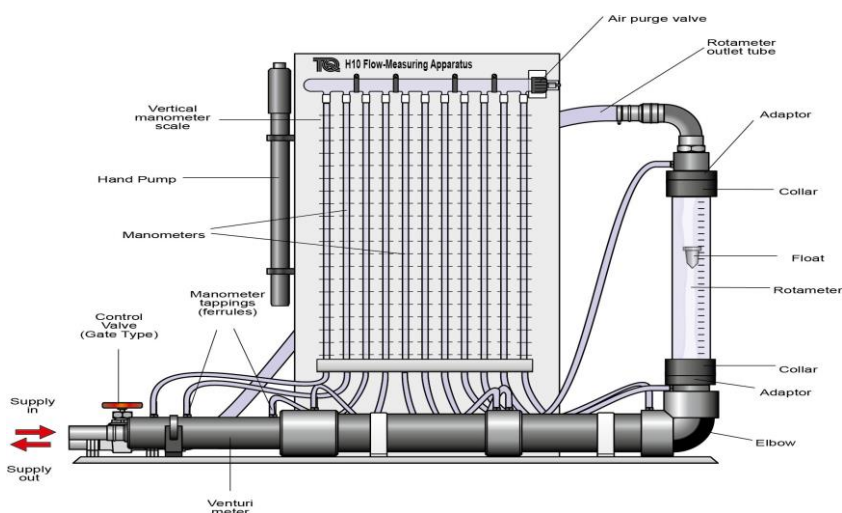

Figure (22): Flow Measurement Methods apparatus.

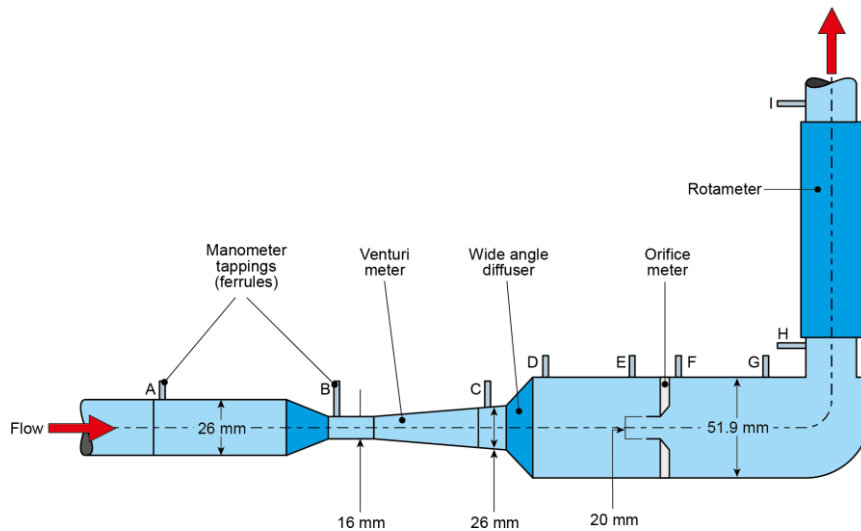

Figure (23): Explanatory Diagram of the Flow Measurement Methods Apparatus.



Figure (24): Digital Hydraulic Bench.

Figures above show the Flow Measurement Methods apparatus, Water-from the Hydraulic Bench-enters the equipment through a Venturi meter, which consists of a gradually converging section, followed by a throat, and a long gradually diverging section. After a change in cross-section through a rapidly diverging section, the flow continues along a settling length and through an orifice meter from a plate with a hole of reduced diameter through which the fluid flows. The water then continues around a bend and up through a rotameter-type flow meter. The H10 has eleven manometers, nine are connected to tappings in the pipework and two are left free for other measurements.

Theory:

The venturi meter, the orifice plate meter and the Rotameter are all dependent upon Bernoulli's equation, for their principle of operation. Bernoulli's equation is given by:

$$\frac{P_1}{\rho \cdot g} + \frac{u_1^2}{2 \cdot g} + z_1 = \frac{P_2}{\rho \cdot g} + \frac{u_2^2}{2 \cdot g} + z_2 + \Delta h_{12} \dots \dots \dots (1)$$

Where (Δh_{12}) is head loss due to friction and localized effects (area change or fitting) and u is the velocity of water.

In order to obtain the total head loss due to fitting we therefore have to correct the measured head loss for the change in velocity head also subtract the head loss due to friction:

$$\Delta H = (h_1 - h_2) + \frac{u_1^2 - u_2^2}{2 \cdot g} - \Delta h_f \dots \dots \dots (2)$$

$$\text{where } \Delta h_{12} = \Delta H + \Delta h_f \dots \dots \dots (3)$$

where (ΔH) is the head loss due to fitting and (Δh_f) is the head loss due to friction. If the length is small, (Δh_f) can be neglected. The head loss is usually expressed in terms of the loss coefficient (K) defined as:

$$k = \frac{\Delta H}{(u^2/2g)} \dots \dots \dots (4)$$

where (u) is the velocity in the smaller pipe:

a. Venturi Meter:

Since (Δh_{12}) is negligibly small between the ends of a contracting duct application of equation (1) between pressure tapping's (A) and (B) gives:

$$\frac{P_A}{\rho \cdot g} + \frac{u_A^2}{2 \cdot g} = \frac{P_B}{\rho \cdot g} + \frac{u_B^2}{2 \cdot g} \dots \dots \dots (5)$$

and since, by continuity:

$$\dot{m}_A = \rho \cdot u_A \cdot A_A = \dot{m}_B = \rho \cdot u_B \cdot A_B \dots \dots \dots (6)$$

Sub (6) into (1) to get:

$$u_B = \left[\frac{2g}{(1 - (A_B/A_A)^2)} \times \left(\frac{P_A}{\rho \cdot g} - \frac{P_B}{\rho \cdot g} \right) \right]^{\frac{1}{2}} \dots \dots \dots (7)$$

Now

$$Q_{Th} = A_B \cdot u_B$$

$$Q_{Th} = A_B \cdot \left[\frac{2g}{(1 - (A_B/A_A)^2)} \times \left(\frac{P_A}{\rho \cdot g} - \frac{P_B}{\rho \cdot g} \right) \right]^{\frac{1}{2}} \dots \dots \dots (8)$$

This is theoretical valve.

$$Q_{act} = C_v \cdot A_B \cdot \left[\frac{2g}{\left(1 - \left(\frac{A_B}{A_A}\right)^2\right)} \times (h_A - h_B) \right]^{\frac{1}{2}} \dots \dots \dots (9)$$

where (Q_{act}) is the actual flow rate.

(C_v) may found from experiment.

b. Orifice Meter:

The head losses (Δh_{12}) in equation (1) is by no means negligible when applied between (E) and (F). Rewrite the equation with the appropriate symbols.

$$\frac{u_F^2}{2 \cdot g} - \frac{u_E^2}{2 \cdot g} = \frac{P_E}{\rho \cdot g} - \frac{P_F}{\rho \cdot g} \dots \dots \dots (10)$$

Reducing equation (10) in exactly the same way as for venturi meter, the following equation will be obtained:

$$Q_{act} = C_d \cdot A_F \cdot \left[\frac{2g}{\left(1 - \left(\frac{A_F}{A_E}\right)^2\right)} \times (h_E - h_F) \right]^{\frac{1}{2}} \dots \dots \dots (11)$$

where C_d is the coefficient of discharge.

Procedure:

1. Press the on/off switch on the hydraulic Bench to start the pump.
2. Open the apparatus valve until the rotameter shows a reading of approximately 10 mm, when a steady flow is maintained measure the flow with the Hydraulic Bench.
3. During this period, record the readings of the manometers.
4. Repeat this procedure for a number of equidistant values of rotameter readings up to the point in which the maximum pressure values can be recorded from the manometer.

Calculation:

1. Calculate (C_v) , (C_d) , (ΔH) , and k for each of (Q) .
2. Plot (ΔH) against $(u^2/2g)$.
3. Plot (C_v) , (C_d) , against Re .
4. Which type of flow meter would you choose for a low loss piping system?
5. Plot the actual flow against the rotameter scale reading.

References:

1. F.A. Holland, "Fluid Flow for Chemical Engineers ", Arnold, 1980.
2. J.M. Coulson and FF Richardson," Chemical Engineering" Vol.1, Third Edition, 1980, pergamon press.
3. W.L. McCabe and J.C. Smith, "Unite Operations of Chemical Engineering", 3rd Edition, 1976.
4. H10, "Flow Measurement Methods ", User Guide.

Experiment Number -4-

The Performance of a Radial Fan

Objective:

To examine the performance of a radial flow rotor in air over a wide range of operating conditions for impeller with radial blades.

Equipment:

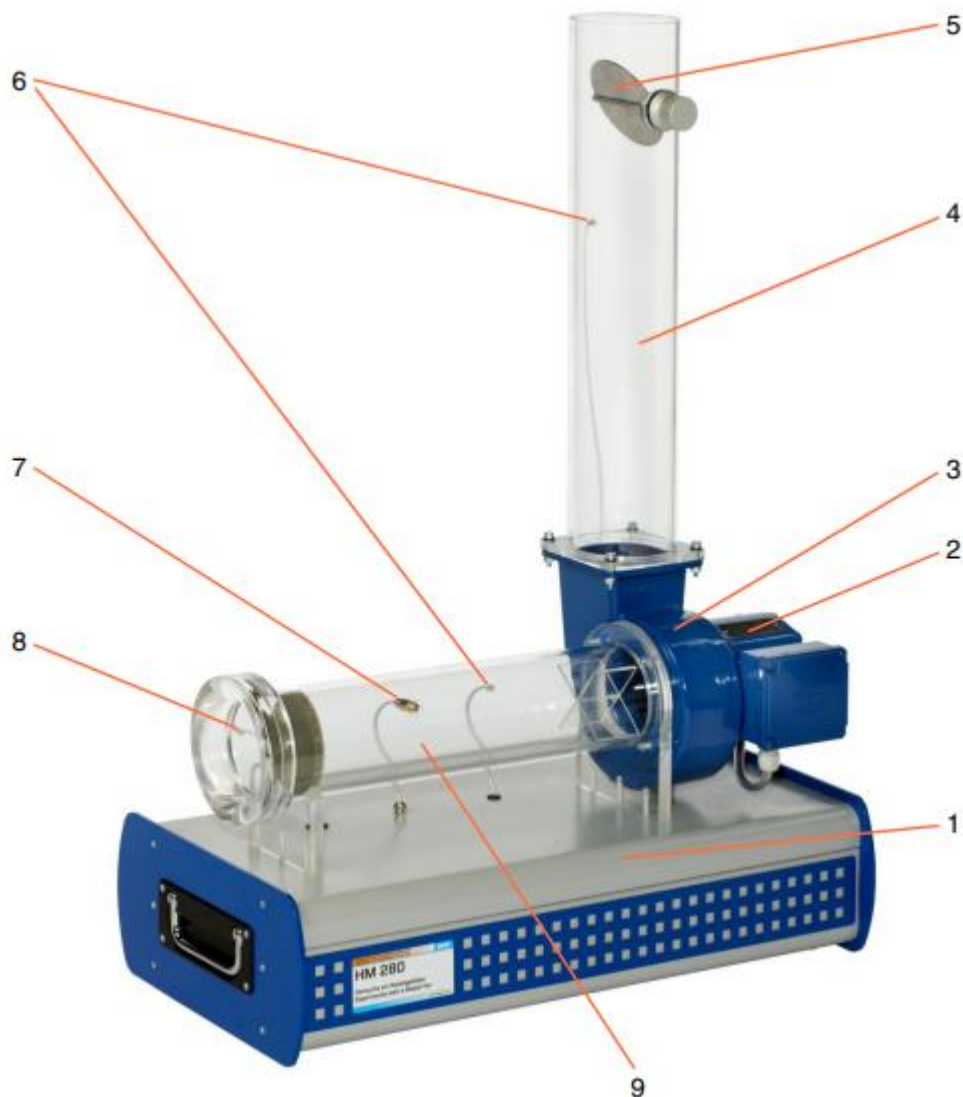

-
- | | |
|-----------------------|--------------------------------|
| 1 Housing | 6 Measuring gauge for dp_F |
| 2 Drive motor (M) | 7 Temperature sensor for T_1 |
| 3 Radial fan (V-R) | 8 Measuring gauge for dp_N |
| 4 Delivery pipe | 9 Intake pipe |
| 5 Throttle valve (V1) | |
-

Figure (1) HM 280-Radial fan overview

The experimental unit essentially consists of the **radial fan (3)** with flange-mounted **drive motor (2)**, the **intake pipe (9)** and the **delivery pipe (4)** with **throttle valve (5)**. The **housing (1)** contains the associated drive technology and instrumentation with a microcontroller board. The drive technology and instrumentation is enabled by **the measurement data acquisition software** and the customer-supplied PC. The **throttle valve** is used to vary the flow resistance in the delivery pipe. The scale on the rotary dial is divided into 10 parts, corresponding to $0^\circ \dots 360^\circ$. In position 0,0 the throttle valve is fully closed. The fully open throttle valve is denoted by the position 2,5. **HM 280** has **two impellers**, which each have a different blade shape.

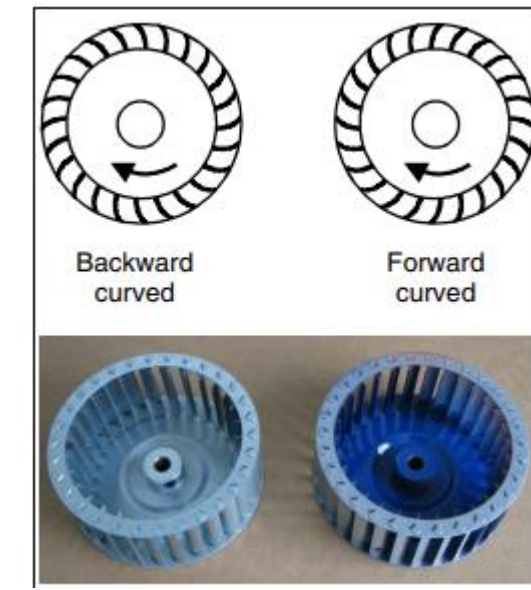

Figure (2) Description of the impellers

Technical data:

Dimensions: Length x width x height: approx. 750 x 350 x 950 mm

Inner diameter intake pipe : 90 mm

Inner diameter delivery pipe: 100 mm

Theory:

Fans are turbo-machines that transfer mechanical energy to a gaseous fluid in the form of hydraulic energy. They convey the gas through a system.

In axial fans, the flow passes through axially to the impeller. In radial fans, the gas exits the impeller radially.

The HM 280 experimental unit is used to measure the differential pressure dp_N between the ambient pressure and the pressure applied at the inflow of the intake pipe. Using dp_N and the known geometry of the intake pipe, the measurement data acquisition program calculate the volume flow of the intake air, known as the suction volume flow \dot{V}_S .

The total pressure composed of static pressure and dynamic pressure. This applies both to the environment and to each flow cross section in the intake pipe.

In this apparatus the cross sectional area at inlet and exit of the fan are almost the same, it follows that velocity heads at inlet and outlet are equal and the fan total pressure is equal to the difference between the corresponding static pressures.

Fan total pressure $P_N = \text{outlet static pressure} - \text{inlet static pressure}$.

While dp_N is therefore measured as the differential pressure between the ambient static pressure and nozzle static pressure, so dp_N is equal to the dynamic pressure behind the inflow nozzle (fan total pressure P_N).

The dynamic pressure dp_N is proportional to the square of the air velocity u . for the calculation:

$$u = \sqrt{\frac{2}{\rho} \cdot dp_N} \dots \dots (1)$$

The suction volume flow \dot{V}_S is proportional to the air velocity u . the proportionality factor is the flow cross section A :

$$\dot{V}_S = u \cdot A \dots \dots (2)$$

$$A = \frac{\pi}{4} \cdot d_i^2 \dots \dots (3) \quad d_i = 90 \text{ mm}$$

Additional influencing factors are the temperature of the intake air T_1 and the ambient pressure P_{amb} , they affect the density ρ of the intake air according to:

$$\rho = \rho_0 \cdot \frac{T_0}{T_1} \cdot \frac{P_{amb}}{P_0} \dots \dots (4)$$

Where $\rho_0 = 1.293 \text{ Kg/m}^3$ is the air density at the reference temperature $T_0 = 273.15 \text{ K}$ and the reference pressure $P_0 = 1013 \text{ mbar}$.

In the present conditions, the conveyed air can be considered incompressible. Therefore, the hydraulic power of the air is the product of pressure increase dp_F and the suction volume flow which expressed simply gives:

$$P_{hyd} = dp_F \cdot \dot{V}_S \dots \dots (5)$$

Where P_{hyd} : Hydraulic power in W , dp_F : Static pressure in N/m^2 , and \dot{V}_S : Volume flow in m^3/s .

The efficiency is defined as the ratio of benefit to effort, the benefit here is the hydraulic power, and the electrical power of the drive motor is expended.

$$\eta = \frac{P_{hyd}}{P_{el}} .100\% \quad \dots \dots \dots (5)$$

Where η : Efficiency in % , P_{hyd} : Hydraulic power (the effort) in W , and P_{el} : the electrical power (the benefit) in W.

Procedure:

In order to record a fan characteristic, the throttling is varied while under constant fan speed

1. Connect experimental unit to the mains power supply.
2. Turn main switch to (1).
3. Start the PC. Start the measurement data acquisition program.
4. Tare values in the system diagram
5. Enter ambient pressure in the system diagram
6. Select "Measurement Diagram" in the program.
7. Enable new series of measurement. Make any setting for the measurement file.
8. Switch on radial fan, select speed of 80%.
9. For the first measurement, close the throttle valve completely(position 0,0)
10. Wait until the displayed measurement is stable.
11. Record measurements (the current measurement data set is written to the **measurement file**).
12. Open the throttle valve a little bit according to the desired number of measurement points.
13. Repeat last two points until the last measurement point is taken with the throttle valve fully open (position 2.5).
14. Repeat steps (4-13) with newly selected seeds 90%, 100%.
15. Save measurements file.
16. Switch of radial fan.
17. Stop the measurement data acquisition program.
18. Main switch to "0".

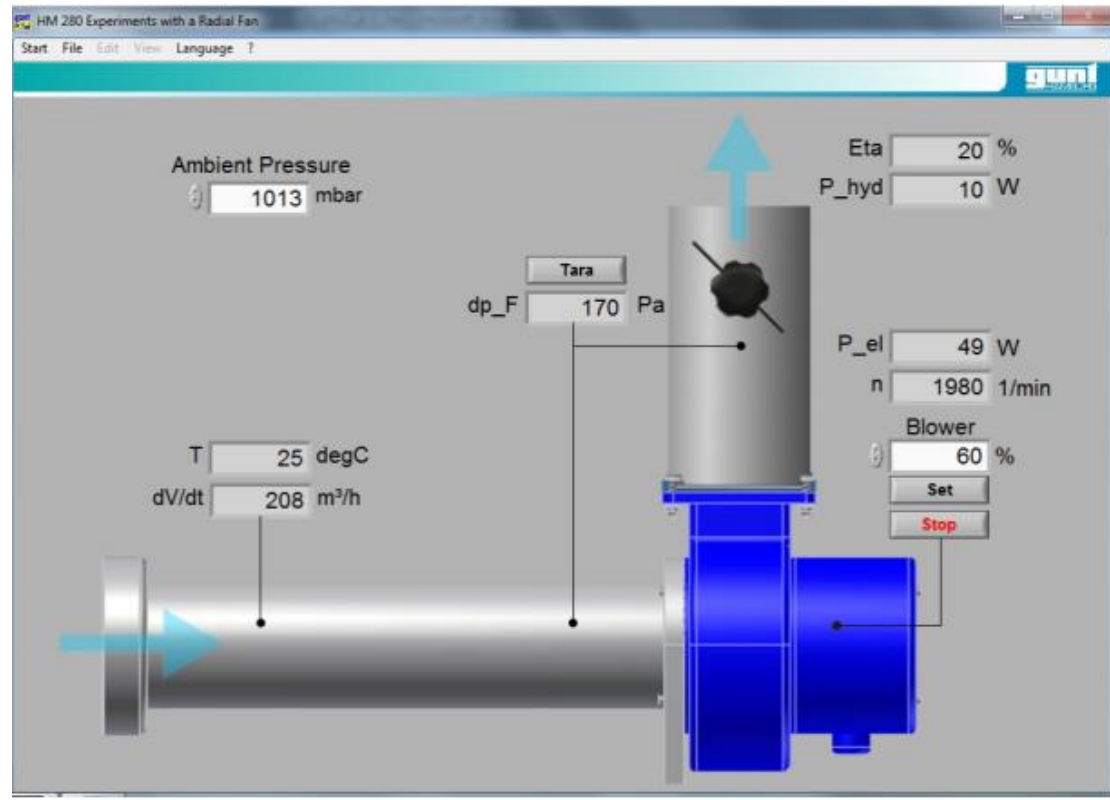

Figure (3) system diagram in the measurement data acquisition program

Calculation:

1. For 80%, 90%, and 100% fan speed, on the same figure using different scales, plot the electrical power of the motor, pressure increase (dp_F), hydraulic power, and the efficiency against the volumetric flow in m^3/h .
2. Comment on any points of general interest which arise from the test results.
3. Can this type of fan test be used to predict the performance of a geometrically similar pump proposed for drainage scheme?

References:

1. F.A. Holland, "Fluid Flow for Chemical Engineers ", Arnold, 1980.
2. J.M. Coulson and FF Richardson," Chemical Engineering" Vol.1, Third Edition, 1980, pergamon press.
3. HM 280 experiments with radial fan experiment instructions, Gunt.

The Performance of a Radial Fan Data Sheet

Description	Unit	Measurements						
Speed 80%								
Fan speed n	min^{-1}							
Differential pressure, inflow dp_N	Pa							
Pressure increase dp_F	Pa							
Temperature of the intake air T_I	$^{\circ}\text{C}$							
Electrical power of the drive motor P_{el}	W							
Ambient pressure P_{amb}	mbar							
Suction volume flow \dot{V}_S	m^3/h							
Hydraulic power P_{hyd}	W							
Efficiency η	%							

Description	Unit	Measurements						
Speed 90%								
Fan speed n	min^{-1}							
Differential pressure, inflow dp_N	Pa							
Pressure increase dp_F	Pa							
Temperature of the intake air T_I	$^{\circ}\text{C}$							
Electrical power of the drive motor P_{el}	W							
Ambient pressure P_{amb}	mbar							
Suction volume flow \dot{V}_S	m^3/h							
Hydraulic power P_{hyd}	W							
Efficiency η	%							

Description	Unit	Measurements						
Speed 100%								
Fan speed n	min^{-1}							
Differential pressure, inflow dp_N	Pa							
Pressure increase dp_F	Pa							
Temperature of the intake air T_I	$^{\circ}\text{C}$							
Electrical power of the drive motor P_{el}	W							
Ambient pressure P_{amb}	mbar							
Suction volume flow \dot{V}_S	m^3/h							
Hydraulic power P_{hyd}	W							
Efficiency η	%							

Instructor signature:

Date

Experiment Number -5-

Shell and Tube Heat Exchanger

Objective:

1. To perform energy balances across a Shell and Tube Heat Exchanger and calculate the Overall Efficiency at different fluid flow rates.
2. To demonstrate the differences between co-current flow (flows in same direction) and countercurrent flow (flows in the opposite direction), and the effect on heat transfer coefficient and temperature efficiencies
3. To determine the Overall Heat Transfer Coefficient for a Shell and Tube Heat Exchanger using the Logarithmic Mean Temperature Difference to perform the calculations (for co-current and countercurrent flow).
4. To investigate the effect of changes in hot and cold fluid flow rate on the Temperature Efficiencies and Overall Heat Transfer Coefficient.

Equipment:

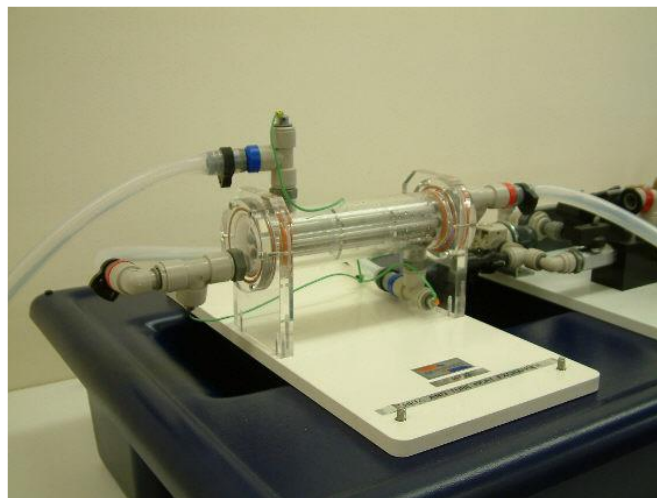

Figure (1): Shell and Tube Heat Exchanger

The shell and tube heat exchanger is commonly used in the food and chemical process industries. This type of exchanger consists of a number of tubes in parallel enclosed in a cylindrical shell. Heat is transferred between one fluid flowing through the tubes and another fluid flowing through the cylindrical shell around the tubes.

In this miniature exchanger, baffles inside the shell increase the velocity of the fluid and hence the rate of heat transfers. The exchanger has one shell and seven tubes with two transverse baffles in the shell.

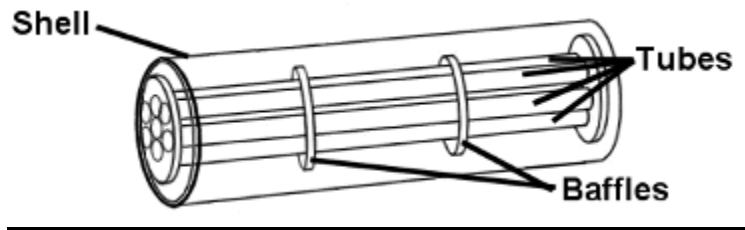

Figure (2): Parts of the exchanger

In normal operation the hot fluid from the hot water circulator enters the header at one end of the shell and passes through the bundle of stainless steel tubes.

The cold fluid from the cold water supply passes through the cylindrical shell. This arrangement minimizes heat loss from the exchanger without the need for additional insulation and allows the construction of the exchanger to be viewed.

The outer annulus, caps and baffles are constructed from clear acrylic to allow visualization of the heat exchanger construction and minimize thermal losses. These provide a liquid seal, accommodate differential expansion between the metal and plastic parts and allow the inner metal tubes to be removed for cleaning.

'O' ring seals allow differential expansion between the metal and plastic parts and allow the inner metal tubes to be removed for cleaning. The end housings incorporate the necessary fittings for sensors to measure the fluid temperatures and connections to the hot and cold water supplies, which is colored coded red for hot water and blue for cold water.

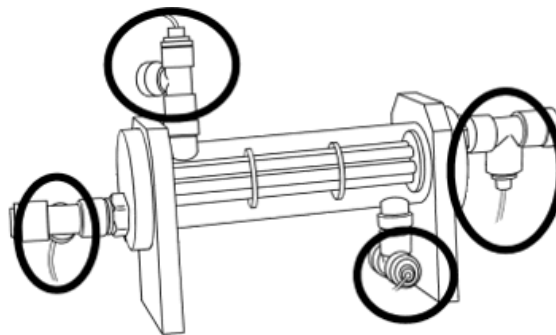

Figure (3): 'O' ring seals

Four thermocouple temperature sensors are labeled T_1 to T_4 for identification and each lead is terminated with a miniature thermocouple plug for connection to the appropriate socket.

Theory:

If the fluids flow through the exchanger in the same direction, then the unit is said to operate in parallel or co-current flow. Flow in opposite direction is called counter-current flow.

The mass flow rate can be calculated from the volumetric flow rate as flow:

$$m = \dot{V} * \rho \dots \dots \dots (1)$$

where:

m: mass flow rate (kg/s)

\dot{V} : volumetric flow rate (m³/s)

ρ : density of the fluid in (kg/m³)

Then the heat duty Q calculated from the equation (2):

$$Q = m \cdot c_p \cdot \Delta T \dots \dots \dots (2)$$

therefore:

$$Q_e = m_h \cdot c_{phot} \cdot (T_1 - T_2) \dots \dots \dots (3)$$

$$Q_a = m_c \cdot c_{pcold} \cdot (T_4 - T_3) \dots \dots \dots (4)$$

Then:

$$Q_l = Q_e - Q_a \dots \dots \dots (5)$$

and the overall heat transfer efficiency can be calculated from equation:

$$\eta_{overall} = \frac{Q_{absorbed}}{Q_{emitted}} \dots \dots \dots (6)$$

where:

Q_e : Heat power emitted from hot fluid (W)

Q_a : Heat power absorbed by cold fluid (W)

Q_l : Heat power lost or gained (W)

m_h, m_c : mass flow rate for hot and cold fluid respectively (kg/s).

C_{phot} : specific heat capacity for hot fluid (kJ/kg.K)

C_{pcold} : specific heat capacity for cold fluid (kJ/kg.K)

T_1, T_2 : hot fluid inlet or outlet temperatures (according to flow direction) (°C).

T_3 : cold fluid inlet temperatures (°C).

T_4 : cold fluid outlet temperatures (°C).

For the overall heat transfer coefficient:

$$U = \frac{Q_e}{A \cdot L_{MTD}} \dots \dots \dots (7)$$

where:

U: the overall heat transfer coefficient referred to area A (W/m².K).

A: the heat transfer area required in the exchanger (m²).

L_{MTD} : the mean temperature difference between the two fluids.

The heat transmission area (A) in the exchanger must be calculated using the arithmetic mean diameter of the inner tubes.

$$d_m = \frac{d_o + d_i}{2} \dots \dots \dots (9)$$

where:

d_m : is the arithmetic mean diameter (m) (d_m can be used since $r_2/r_1 < 1.5$ otherwise the logarithmic mean radius d_{lm} must be used).

d_i : inner tube inside diameter = 0.00515(m).

d_o : inner tube outside diameter = 0.00635(m).

Heat transmission length $L = n.l$ (m)

where n = number of tubes = 7

l = heat transmission length of each tube = 0.144 (m)

then $L = 1.008$ (m)

and the heat transmission area:

$$A = \pi \cdot d_m \cdot L \dots \dots \dots (8)$$

The overall heat transfer efficiency can be calculated from equation:

And the thermal efficiency for the cold side:

$$\eta_{cold} = \frac{\Delta T_{cold}}{\Delta T_{max}} \dots \dots \dots (3)$$

And the thermal efficiency for hot side:

$$\eta_{hot} = \frac{\Delta T_{hot}}{\Delta T_{max}} \dots \dots \dots (4)$$

Where:

$$\Delta T_{cold} = T_{c.out} - T_{c.in}$$

$$\Delta T_{hot} = T_{h.in} - T_{h.out}$$

$$\Delta T_{max} = T_{h.in} - T_{c.in}$$

Then the efficiency of exchanger = $\frac{\eta_{cold} + \eta_{hot}}{2}$.

Procedure:

1. Set the temperature controller to 60°C.
2. Set the hot water valves to have co-current direction.
3. Adjust the cold water control valve setting to give a cold water flow rate of 2litre/min.
4. Click on the button for the hot water flow rate controller, set the controller to Automatic and enter a Set Point value of 1 liters/min. Apply and click 'OK'.

5. Allow the temperatures to stabilize for 10 min, and then select the icon (Go) to record the following, or manually note the values: T_1 , T_2 , T_3 , T_4 , F_{hot} , F_{cold} .
6. Adjust the hot water control valve to give 2 liters/min.
7. Allow the heat exchanger to stabilize then repeat the above readings with 3, 4, 5 liters/min for hot water flow rate.
8. Repeat with counter flow direction.

Calculation:

1. Calculate the heat duty emitted, absorbed, and lost.
2. Calculate the efficiency of the exchanger for both co-and counter arrangement.
3. Calculate the overall heat transfer coefficient.
4. Calculate the temperature efficiency of the heat exchanger.
5. Plot the temperature profile for both the co-current and counter current at one and same hot water flow rate.
6. Plot the efficiency of the exchanger with the hot water flow rate.

References:

1. Coulson J.M. and Richardson J.F., "Chemical Engineering", Volume 1, 2nd Edition, Pergamon Press.
2. Kern D.Q., "Process Heat Transfer ", McGraw Hill.
3. Perry R.H., Chilton C.H., "Chemical Engineering Handbook". 5th Edition, MacGraw Hill.
4. Armfield Instruction manual, Shell and tube heat Exchanger HT33, ISSUE 17, November 2015.

Shell and Tube Heat Exchanger Data Sheet

Cold water flow rate: _____

Co-current flow:

Hot water flow rate (Liter/min)	$T_{hot,in}$ (°C)	$T_{hot,out}$ (°C)	$T_{cold,in}$ (°C)	$T_{cold,out}$ (°C)

Counter-current flow:

Hot water flow rate (Liter/min)	$T_{hot,in}$ (°C)	$T_{hot,out}$ (°C)	$T_{cold,in}$ (°C)	$T_{cold,out}$ (°C)

Instructor signature: _____

Date: _____

Experiment Number -6-

Concentric Tube Heat Exchanger

Objective:

1. To demonstrate the working principles of a concentric tube heat exchanger operating under co-and counter flow arrangements.
2. To demonstrate the effect of hot water temperature variation, flow rate variation on the performance characteristics of a concentric tube heat exchanger.

Equipment:

A supply of hot water at temperature up to 80°C is maintained in a storage tank at the rear of the apparatus by an integral heating element. Power to the electric element is regulated by a controller, which is mounted on the front panel and incorporates a decade switch to set the desired water temperature, a deviation meter to indicate the deviation of the water temperature from the set point. Water is continuously recirculated through the tank by a pump.

Hot water for the exchanger is taken from the pump discharge and passes through the inner pipe of the concentric tube arrangement before returning to the tank for reheating. Flow through this circuit is regulated by a control valve (18) and indicated at the flow meter (19). Thermometer (15) and (17) installed at the inlet, midpoint and outlet of the exchanger hot water circuit indicate the respective water temperature. As shown in figure (4)

Cold water for the exchanger is supplied from an external source to the outer annulus of the concentric tube arrangement. Co-or counter-flow configuration may be obtained by appropriate setting of the selector valve (16). Valve (11) at the top of the exchanger permits air to be bled from the system and facilitate drainage.

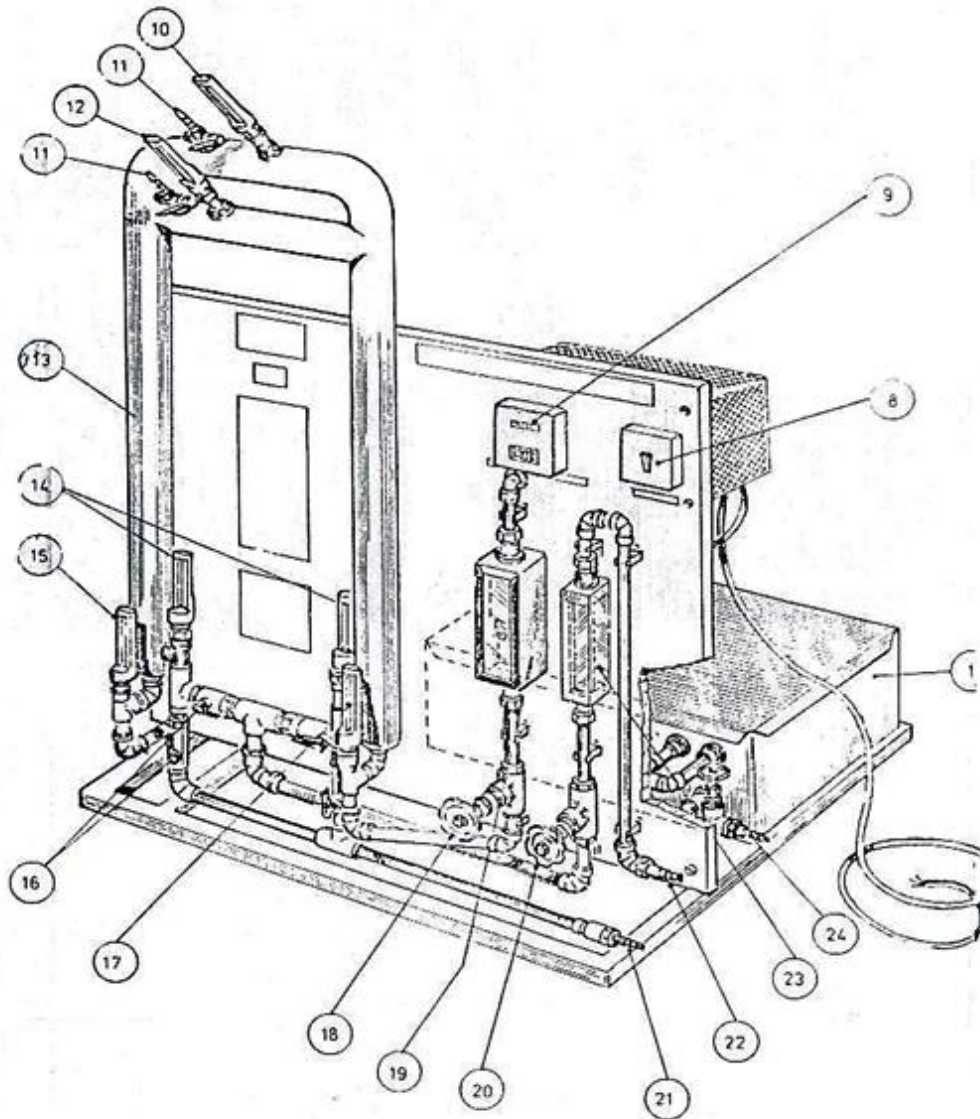

Figure (4): Schematic diagram for concentric tube heat exchanger.

Theory:

One of the simplest forms of heat exchanger is the so-called double-pipe exchanger. One of the fluids passes through the tube whilst the second fluid flows through the annular space. If the fluids flow through the exchanger in the same direction, then the unit is said to operate in parallel or co-current flow. Flow in opposite direction is called counter-current flow. The duty Q of the exchanger can be calculated from the change/unit time in sensible heat content of a fluid being heated or cooled, and/or the latent heat extracted or supplied in condensation or evaporation processes respectively.

In terms of heat transfer, the duty of the exchanger can be described by the simple equation:

$$Q=U.A. (LMTD).....(1)$$

where:

U : the overall heat transfer coefficient referred to area A .

A : the heat transfer surface required in the exchanger.

L_{MTD} : the mean temperature difference between the two fluids.

The overall heat transfer efficiency can be calculated from equation:

$$\eta_{overall} = \frac{Q_{absorbed}}{Q_{emitted}} \dots \dots \dots (2)$$

And the thermal efficiency for the cold side:

$$\eta_{cold} = \frac{\Delta T_{cold}}{\Delta T_{max}} \dots \dots \dots (3)$$

And the thermal efficiency for hot side:

$$\eta_{hot} = \frac{\Delta T_{hot}}{\Delta T_{max}} \dots \dots \dots (4)$$

Where:

$$\Delta T_{cold}=T_{c.out}-T_{c.in}.$$

$$\Delta T_{hot}=T_{h.in}-T_{h.out}.$$

$$\Delta T_{max}=T_{h.in}-T_{c.in}.$$

Then the efficiency of exchanger equal $\frac{\eta_{cold}+\eta_{hot}}{2}$.

Procedure:

1. Fill the storage tank with clean water.
2. Close the air bleed valve (11) at the top of the heat exchanger.
3. Connect the cold water inlet to a source of cold water using flexible tubing.
4. Close the hot water flow control valve (18).
5. Set the selector switch on the side of the pump motor to the maximum setting.
6. Set the temperature controller to zero using the decade switches on the front panel.
7. Set the electrical supply switch on the ON position and observe operation of the pump.
8. Open the hot water flow control valve (18) to a medium value and allow water to flow through the exchanger until a steady flow of water is indicated on hot flowmeter (19).
9. Open the cold water flow control valve. Set the selector valves to co-current position. Allow water to flow through the exchanger until a steady flow of water is indicated on the cold flowmeter.
10. Set the temperature controller to 50°C.
11. Take the thermometers readings once they are stabilized as well as the flowrates on the flowmeters.
12. Increase the controller set point to 60°C, 70°C, 80°C and note the thermometers readings.
13. Set the controller temperature to 60°C and change the flowrate of hot water, making sure to note the readings of the thermometers for each flowrate.
14. The above procedure can be repeated for counter current.

Calculation:

7. Calculate the efficiency of the exchanger for both co-and counter arrangement.
8. Calculate the overall heat transfer coefficient.
9. Calculate the temperature efficiency of the heat exchanger.
10. Plot the temperature profile for both the co-current and counter current.

References:

5. D.Q. kern, "Process Heat Transfer ". McGraw Hill, 1982.
6. Coulson & Richardson, "Chemical Engineeringing ", Vol. 1.1980.

Concentric Tube Heat Exchanger Data Sheet

Heat transfer area: _____

Heat transfer length: _____

Cold water flow rate: _____

Co-current flow:

Hot water flow rate (cm ³ /min)	T _{hot,in} (°C)	T _{hot,out} (°C)	T _{cold,in} (°C)	T _{cold,out} (°C)

Counter-current flow:

Hot water flow rate (cm ³ /min)	T _{hot,in} (°C)	T _{hot,out} (°C)	T _{cold,in} (°C)	T _{cold,out} (°C)

Instructor signature: _____

Date: _____

Experiment Number -7-

Heat Conduction

Objective:

1. To measure the temperature distribution for steady state conduction of energy through a uniform cross-section and demonstrate the effect of a change in heat input.
2. To determine the thermal conductivity of a material and the effect of temperature on thermal conductivity.
3. To measure the application of poor thermal conductors and determine the thermal conductivity K of a poor thermal conductor.

Equipment:

The unit consists of a heat service unit, supplying a variable A.C. voltage to vary heater power. A heat conduction unit and 12 type K thermocouple sockets allow connection of this unit to the service unit. Three fixed thermocouples T₁, T₂, T₃, are positioned along the heated section at 15 mm intervals. Three fixed thermocouples T₆, T₇, T₈, are positioned along the cooled section at 15 mm intervals, and four intermediate sections are supplied to place between the heated and cooled sections. Water for the cooled section is supplied from the tap via a hose.

The specimens are brass or stainless steel of 30 mm and 25 mm diameter.

Theory:

The fundamental law of heat conduction is that of Fourier:

$$Q = -KA \frac{dT}{dx}$$

Q: is the rate of heat input.

K: is the thermal conductivity.

x: is the distance from the hot end.

T: is the temperature.

The negative sign being inserted because the heat is flowing towards the lower temperature face.

Integrating the above equation gives.

- a. For linear conduction through a uniform bar.

$$Q = -KA \frac{T_1 - T_2}{L}$$

- b. For radial conduction through a cylinder.

$$Q \ln \frac{R_2}{R_1} = 2\pi KL(T_1 - T_2)$$

where :

A: is the cross-sectional area of the bar.

L: is the length of the specimen.

R₁ and R₂: is the radius of the specimen at T₁ and T₂.

Procedure:

1. Ensure that the main switch is in the off position and the voltage controller is in the anti-clockwise position.
2. Make sure that the heat transfer unit is connected to the heat transfer service unit, and the specimen is installed in the heat transfer unit.
3. Open the water tap until the water flows through the drain.
4. Turn on the main switch and set the temperature selector switch to T₁.
5. Rotate the voltage controller clockwise to increase the voltage to the specified value, and observe the temperature T₁.
6. Allow the system to reach stability and take the reading of temperatures, voltage and current.
7. Repeat at different heat input or different specimens.
8. It is possible to connect the unit to the computer via the interface to monitor and record the temperature along the specimen, and have them on a printer paper. (You have to follow the instruction of your supervisor).

Calculation:

1. Draw graph of temperature gradient at steady state at different heat input.
2. Draw graph of temperature variation with time.
3. Calculate the thermal conductivity of the material under investigation and investigate the effect of changing heat transfer coefficient on the conductivity.

References:

Christie J. Geankolis, "Transport Processes and Unit Operation", 3rd Edition, Perntic Hall.

Experiment Number -8-

Free and forced convection

Objective:

- To study how heat convects from a choice of three different surfaces (flat plate, pinned surface, and finned surface) both under free convection and under forced convection.
- To determine free and forced convection heat transfer coefficient for the three surfaces.

Equipment Description:

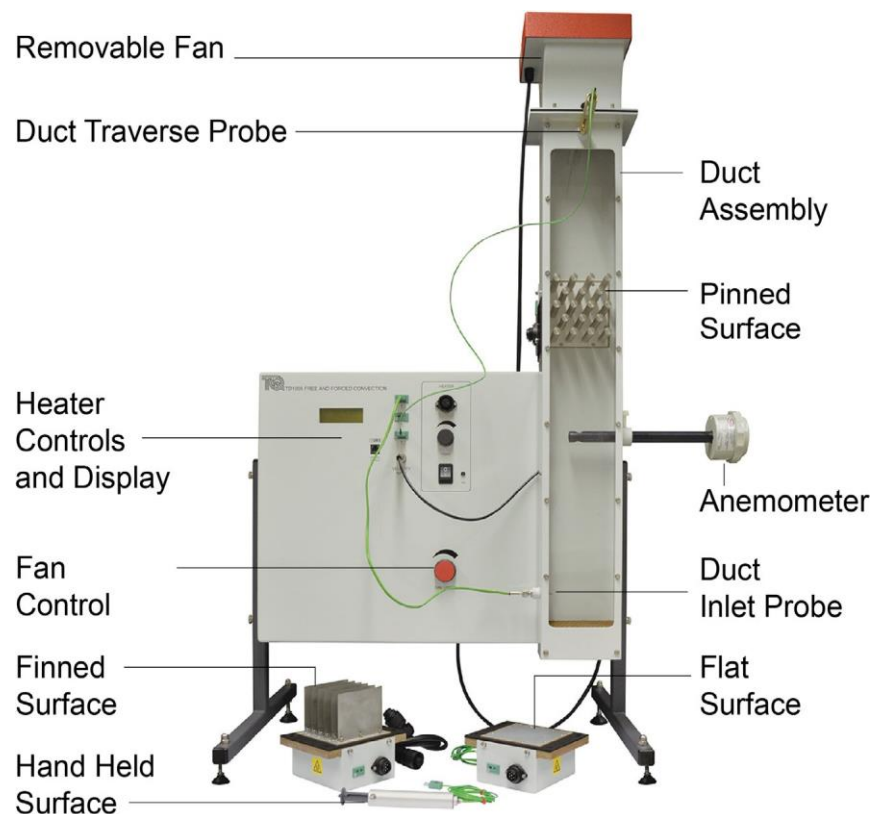

Figure 1: the free and forced convection apparatus (TD1005)

The Main Unit is a compact bench-mounting frame that connects to a suitable electrical supply. It has a vertical duct assembly and a main 'Control Panel' with electrical controls and displays.

Each of the three heat transfer surfaces (supplied) fit into the back of the vertical duct, at just above half-way up the duct.

The vertical duct allows air to pass over the heat transfer surface, both by free convection, or by forced convection using a removable variable speed electric fan at the top of the duct. A fixed thermocouple probe measures the inlet (ambient) air temperature in the duct. A movable thermocouple probe in a traversing mechanism allows measurement of the temperature distribution across the duct at the outlet. This allows students to find the bulk outlet temperature for the more advanced calculations. An anemometer measures air velocity in the duct.

Each heat transfer surface includes a built-in thermocouple to measure its surface temperature. The equipment also includes a hand-held thermocouple probe for heat distribution measurement along the finned and pinned heat transfer surfaces. The user inserts the probe tip into a selection of six equally-spaced holes in the side of the duct. A magnetic cover allows the holes to be covered completely or so that only one at a time can be used, reducing stray convection caused by the other holes.

The Base Unit supplies safe, low-voltage electrical power to the heater (heat source) in each heat transfer surface and a variable supply for the fan at the top of the duct. The thermocouples in the duct and the thermocouple on the heat transfer surface connect to sockets on the front of the control panel. For heat distribution experiments with the hand-held probe, the user connects the probe to any unused thermocouple socket (not all are used for each experiment). A display on the control panel shows the electrical power supplied to the heater in the heat transfer surface, the air velocity in the duct and the temperature at each of the three thermocouples connected.

A socket on the control panel allows connection to TecEquipment's optional VDAS for data acquisition from this equipment, with the use of a suitable computer

The heat transfer surfaces:

This experiment includes three different heat transfer surfaces to allow students to compare their performance. Each heat transfer surface fits quickly and easily into a square opening in the back side of the duct. A foam gasket around each surface helps to seal it from stray convection when fitted to the duct.

Each heat transfer surface has two sides:

An exposed front side: It has a light grey bare metal finish. This helps to ensure more accurate experiment results because most heat transfer are then by convection rather than radiation (a dark matt black surface increases heat loss by radiation). In actual applications, heat transfer surfaces are often coated matt black to maximize heat transfer by both convection and radiation.

An enclosed back side: This has a surface-bonded electrical heater and a centrally-mounted thermocouple. The heater includes a thermal safety cut-out switch to help prevent overheating. Insulation surrounds the back side. This prevents unnecessary heat loss which would affect the experiment results.



Flat plate:

Figure 2: the flat plate.

This is simply a flat aluminum plate. This surface is unique from the other two, in that it fits completely flush with the inner wall of the duct and has no extra fins or pins that penetrate the duct airflow



Figure 3: the finned surface.

Finned surface:

This is a popular surface design used in for ‘heat sinks’ to transfer heat away from components in electrical and electronic circuits. It effectively increases the available heat transfer surface area to help transfer more heat into the surrounding air (or capture heat from the surrounding air if used in reverse). This surface is useful for a demonstration

of free convection both vertically (up from the fins) and horizontally (with fins horizontal).



Figure 4: the pinned surface.

Pinned surface:

This is a popular surface design used in ‘heat exchangers’, where one fluid flows along the pins (usually hollow tubes) at right angles to the flow of another fluid that passes around the pins. The heat energy in the hotter fluid passes through the surface of the pins or tubes into the colder fluid. Again, as with the finned surface, this surface effectively increases the available heat transfer surface area to help transfer more heat into the surrounding fluid (or air as used here).

Note: all technical details were listed in the appendices.

Theory:

Heat transfers from one body to another by three methods, conduction, convection and radiation. Most real-world heat transfer uses elements of all three. Here in our experiment we are talking about convection, while the heat transfers by a fluid (liquid, air or gas).

Free Convection

This is when the heat transfers from the object under the influence of fluid (air) density changes. The heat energy around the object causes the air density around the surface of the object to decrease. The reduced density air is more buoyant than the surrounding air and rises, transporting the heat energy away naturally. In normal conditions gravity is the main force affecting buoyancy and therefore convection. However, where the object forms part of a rotating machine, centrifugal force can be a driving force for convection.

Forced Convection

This is when an external force moves air around or across the surface. The movement of air transports the heated air away from the object. The higher the air velocity, the faster it transports heat away from the object.

Heat Transfer Coefficient (Convective) (h_c)

Heat transfer coefficient is a material's ability to conduct heat to another material. Convective heat transfer occurs between the surface of a material and a moving fluid. Typical values of heat transfer to air are:

5 to 25 W/m²K in **free** convection

10 to 200 W/m²K in **forced** convection

(Showing that heat transfers to air better in forced convection than it does in free convection).

$$h_c = \frac{Q}{A_s \times T_m} \quad (1)$$

Where Q is the rate of heat energy transfer from the surface to the air in J/s.

A_s is the cross sectional area of the surface in m².

And T_m is the logarithmic mean temperature.

$$T_m = \frac{T_{out} - T_{in}}{\log \frac{T_s - T_{in}}{T_s - T_{out}}} \quad (2)$$

Experiment 1: Free convection.

Note: This experiment works for all three heat transfer surfaces.

Procedures:

1. Remove the fan from the top of the duct.
2. Fit the chosen heat transfer surface.
3. For reference only, take readings of the surface and inlet temperatures with no power applied.
4. Switch on the heater and set to 5 watts power.
5. Wait for the temperatures to stabilize, under free convection, it may take up to 30 minutes for temperatures to stabilize, and then record surface and inlet temperature.
6. Repeat for several more heater powers as shown in the table, stopping before the surface reaches 95°C.
7. If there is time, Repeat the experiment for the other heat transfer surfaces (pinned or finned).
8. Switch off the heater and allow the surface to cool down to near ambient temperature.

Table 1 : result table for flat plate

Heat Transfer Surface: flat plate			
Power (W)	T ₂	T ₁	Difference T _S - T _{IN} (°C)
	Surface T _S (°C)	Duct Inlet (ambient) T _{IN} (°C)	
0			
5			
10			
15			
20			
25			
30			
35			
40			
45			
50			

Result

analysis:

For each table of results, subtract the inlet temperature from the heat transfer surface temperature to complete the results tables. The temperature difference gives a value with respect to ambient, helping to allow for changes in local conditions.

Create a chart of temperature difference against power (horizontal axis). Add to this chart the results from both surfaces to see the relationship and compare results.

Compare the results. Which surface created the highest temperature difference in free convection? What does this say about this surface?

Experiment 2: Forced convection – Effect of velocity

Note: This experiment works for both the pinned and finned heat transfer surfaces.

Procedures:

1. Fit the fan to the top of the duct.
2. Fit either the finned or pinned heat transfer surface.
3. Set the fan to give an air velocity of 1 m/s.
4. Set the heater power to 50 W.
5. Wait for the temperature to stabilize.
6. Record the surface and inlet temperatures.
7. Repeat for increased air velocities of approximately 1.5, 2, 2.5, and 3 m/s.
8. Repeat for the other surface.

Table 2: Results for exp. 2

Heat transfer Surface: Power:			
	T_2	T_1	
Air velocity ($m.s^{-1}$)	Surface T_s ($^{\circ}C$)	Duct Inlet (ambient) T_{in} ($^{\circ}C$)	Difference $T_s - T_{in}$ ($^{\circ}C$)

Result analysis:

for each surface, create a chart of $T_s - T_{in}$ (vertical axis) against velocity.

What does the chart say about temperature and velocity?

Which surface has the coolest temperature for any given air velocity?

Experiment 3: Heat transfer coefficient.

- Heat transfer, by J.P Holman, published by McGraw Hill, ISBN 978-0-07-352936-3.

Experiment Number -9-

Reynolds Number

Objective:

The aim of this experiment is to demonstrate laminar and turbulent flow in a pipe and to determine under which conditions each flow regime occurs.

Practical application:

The Reynolds number has many practical applications, as it provides engineers with immediate information about the state of flow throughout pipes, streams and soils helping them apply the proper relationships to solve the problem at hand. As an example, if forces acting on a ship need to be studied in the laboratory for design purposes, the Reynolds number of the flow acting on the model in the lab and on the prototype in the field should be the same.

Equipment:

The following equipment is required to perform the Reynolds number experiment:

- The HM 150.18 Osborne Reynolds experiment device.
- Cylinder for measuring flow.
- Stopwatch for timing the flow measurement.
- Thermometer.

The experimental setup allows laminar and turbulent flow to be demonstrated. The flow is made visible with an ink trace in a transparent pipe section.

Equipment Description:

The equipment includes a vertical head tank **water reservoir (9)** that provides a constant head of water with a **glass ball layer (4)** to stem the flow of water entering the pipe. The inlet of water is from the laboratory **water supply (12)** and regulated by a **control valve (11)**, while the discharge of waste water is from **water discharge (2)**, the **overflow section (10)** is to generate a constant pressure level in the reservoir.

An **Aluminum reservoir (8)** for ink is mounted on the top of the head tank with **metering tap (7)** and **brass inflow tip (6)**, from which a blue ink can be injected into the water by **test pipe section (3)** with flow **optimized inflow (5)** to enable observation of flow conditions. **Drain valve (1)** to adjust the flow through the test pipe section.

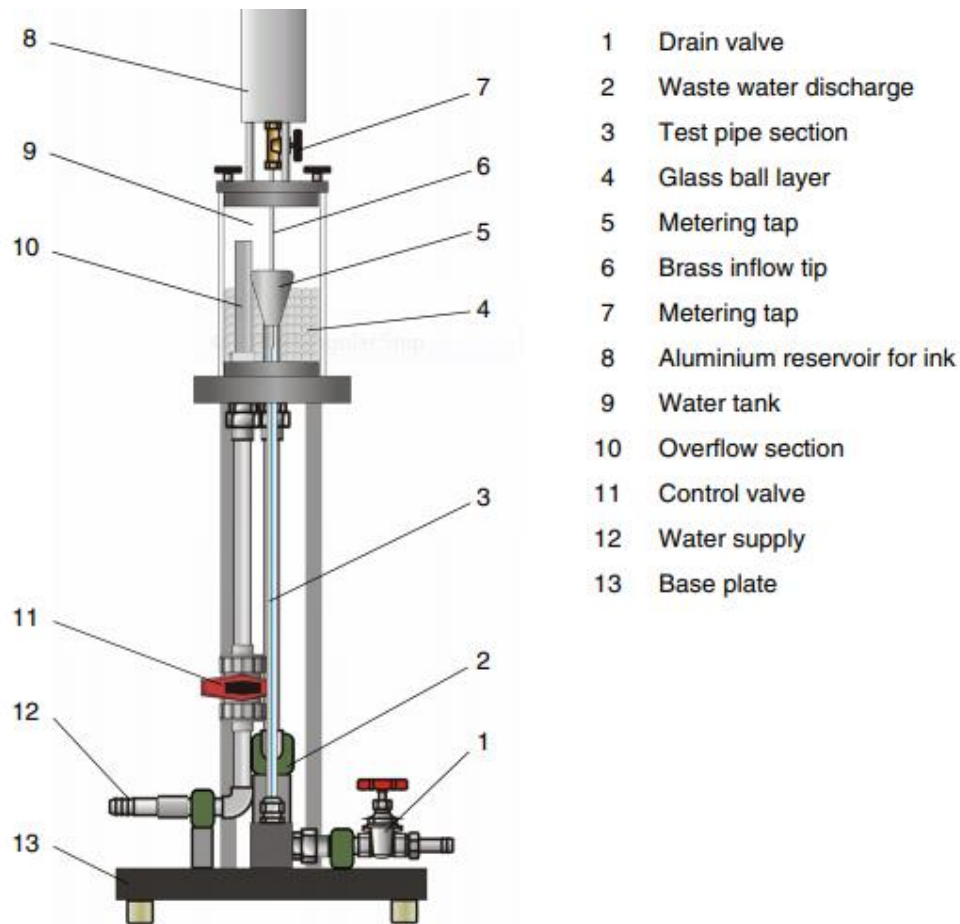

Figure (1) Unit description HM 150.18

Theory:

Flow behavior in natural or artificial systems depends on which forces (inertia, viscous, gravity, surface tension, etc.) predominate. In slow moving laminar flows, viscous forces are dominated and the fluid behaves as if the layers are sliding over each other. In turbulent flows, the flow behavior is chaotic and changes dramatically, since the inertial forces are more significant than the viscous forces.

In this experiment the ink injected into a laminar flow will form a clear well-defined line. It will mix the water only minimally, due to molecular diffusion. When the flow in the pipe is turbulent, the ink will rapidly mix with the water, due to the substantial lateral movement and energy exchange in the flow.

There is also a transitional stage between laminar and turbulent flows, in which the ink stream will wander about and show intermittent bursts of mixing, followed by a more laminar behavior.

The Reynolds number (Re) provides a useful way of characterizing the flow, it is defined as:

$$Re = \frac{V \cdot d}{\nu} \quad \dots (1)$$

Where :

d : is the inside diameter of pipe section in m

V : is the mean flow velocity in m/s

ν : is the kinematic viscosity of the water in $\text{m}^2/\text{s} = 1 \times 10^{-6} \text{m}^2/\text{s}$

The flow rate can be calculated from the volume flow, which is determined with a measuring vessel and a stopwatch.

$$Q = V \times A \quad \dots (2)$$

$$A = \frac{\pi d^2}{4} \quad \dots (3)$$

Where :

- Q : Volumetric flow rate m^3/s
- A : Cross-sectional area of the pipe
- d : Pipe diameter , m = 10 mm

Reynolds number is dimensionless parameter that is the ratio of the inertial force to the viscosity force. As Reynolds increases, the inertial force becomes relatively larger, and the flow destabilizes and becomes fully turbulent.

The Reynolds experiment determines the critical Reynolds number for pipe flow at which (critical $Re \approx 2300$), and the laminar flow where ($Re \leq 2300$), while the turbulent flow occurs when ($Re \geq 2300$).

The diagram below shows the three flow states:

- Laminar flow
- Transition laminar/turbulent flow
- Turbulent flow

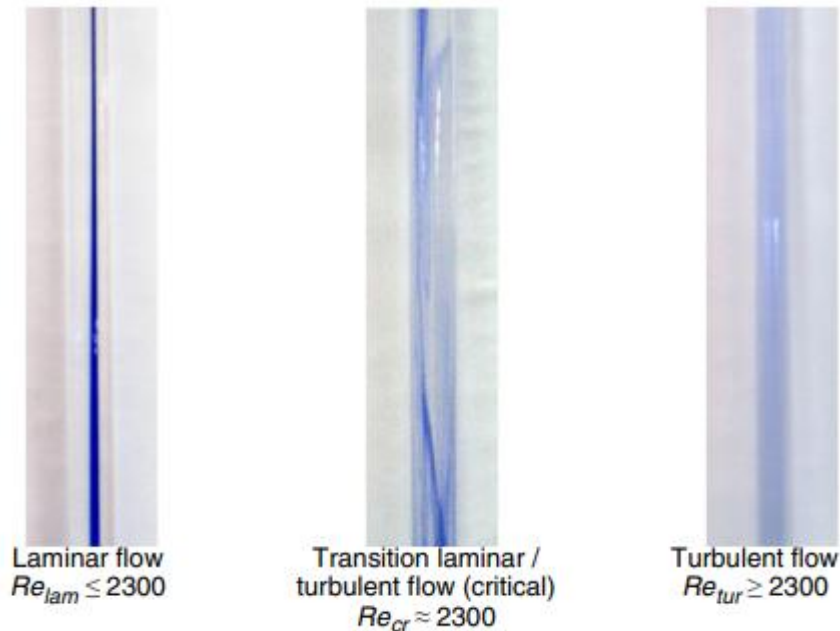

Figure (2) Flow states

Technical data:

- | | |
|---------------------------------------|---------------------------|
| 1. Length x width x height | 420 mm x 420 mm x 1170 mm |
| 2. Water tank capacity | approx. 2.2 L |
| 3. Ink reservoir capacity | approx. 250 ml |
| 4. Test pipe section diameter, length | 10 mm, 675 mm |

Experimental Procedure:

Notice: The device should be level, fixed, on vibration-free surface, and ensure that the base is horizontal and the test section is vertical.

- Close the drain valve (1)
- Switch on the water supply
- Carefully open the control valve (11). The water supply should be done without air bubbles.
- Adjust the ball valve (11), so that, with the drain tap (1) closed, a constant water level is established above the overflow in the reservoir.

- After a time the test pipe section (8) is completely filled with water. Any entrained air bubbles that still hold between the glass balls should be removed as far as possible.
- The experiment can begin.
- Open the drain cock (1) slightly to produce a low rate of flow into the test pipe section. The colored waste water is best directed down the drain.
- For laminar flow (small flow) the water drain is to be turned so far that only a small jet or drops are to be perceived, then a fine blue line appears until the outlet.
- For turbulent flow (greater flow), the drain cock is opened wider to produce a high flow. The current thread is broken up, it shows turbulence to the out.
- Measure the flow volumetric rate by timed water collection.
- Observe the flow pattern, take pictures, and classify the flow regime.
- Measure water temperature.
- When finished, return the remaining ink to the storage container and rinse the container with clean water to ensure that no ink is left in the tank and valve.
- Drain water from water tank, if necessary clean it.
- Shut of the water supply to the device.
- Open valves and drain residual water from the lines.

Calculations:

Calculate discharge flow velocity and Reynolds number (Re), classify the flow based on the Reynolds number of each trial.

Conclusions:

Discuss your results, focusing on the following:

1. How is the flow pattern of each of the three states of flow different?
2. Does the observed flow condition occur within the expected Reynolds number range for that condition?
3. Discuss your observation and any source of error in the calculation of the number.
4. Compare the experimental results with any theoretical studies you have undertaken.

Reynolds Number Experiment Data Sheet

Raw data:

Trial	Observed flow regime	Volume (L)	Time (sec)	Temperature °C
1				
2				
3				
4				
5				
6				
7				

Instructor signature:

Date:

Experiment Number - 10 - Pressure Gauge Calibrator

1. Objective:

To show how the gauge works and how to calibrate it.

2. Equipment and materials:

The TecQuipment Calibration of a Pressure Gauge uses a large Bourdon pressure gauge, with 'dead weights' on a plunger piston to show how the gauge works and how to calibrate it.



Figure (1): Calibration of a Pressure Gauge (H3a)

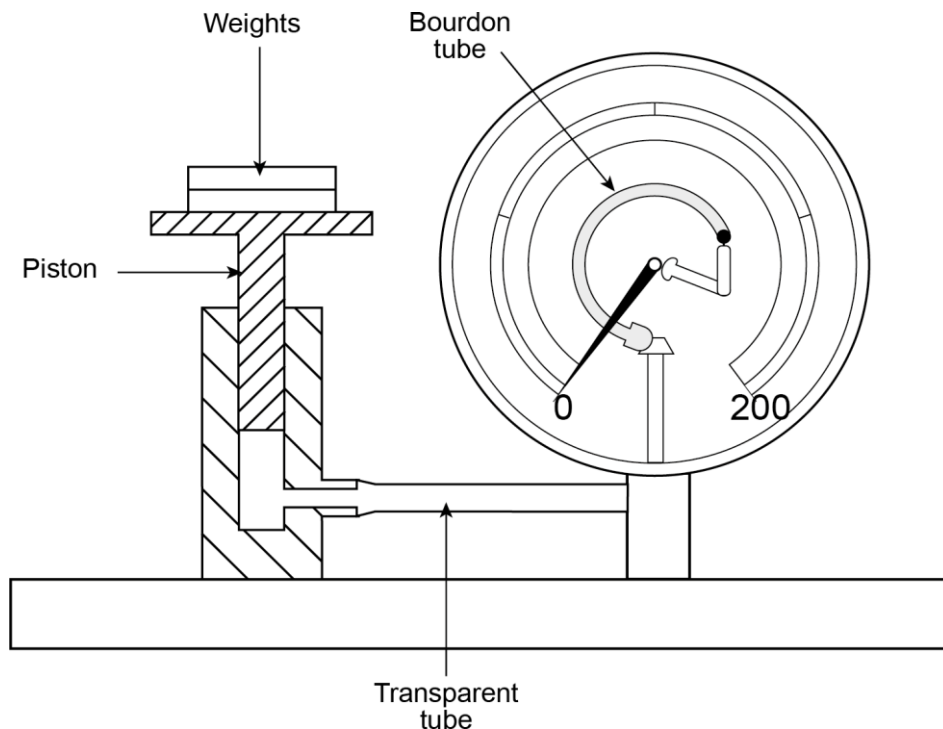

Figure (2) : Principle of the Bourdon Pressure Gauge Calibrator

- The transparent dial of the instrument allows the workings of the gauge to be seen.
- A thin-walled tube with an oval cross-section forms a 270° circular arc.
- The tube has one end fixed and open to the applied pressure. Its other end is sealed but free to move.
- As pressure enters the fixed end, the tube tries to straighten. This causes movement at the free end which moves a mechanical system connected to a pointer.
- The pointer moves around a graduated scale in proportion to the pressure applied. The sensitivity of the gauge depends on the material and dimensions of the Bourdon tube.
- A piston and cylinder assembly to the side of the gauge allows the addition of known values of accurately calibrated weights, which force water towards the gauge, increasing the pressure in the Bourdon tube.
- The pressure shown by the Bourdon gauge should match the pressure calculated from the force created by the weights, with an accuracy determined by experiment.
- The Bourdon gauge may have scales calibrated in both SI derived units of kN.m^{-2} and non-SI units of lb.in^{-2} .
- The gauge could be calibrated using the non-SI units but the experiments in this guide only show the use of the SI derived units.

- SI = International System of Units

3. Theory:

Symbol	Meaning	Units
A	Area	m^2
g	Acceleration due to gravity	9.81 m.s^{-2} or 9.81 m/s^2
m	Mass	kg
p	Pressure	Pa or N.m^{-2} or N/m^2
W	Weight (force)	N

Units of Pressure

- The standard units of pressure are the Pascal (Pa) and Newtons per square metre (N.m^{-2}), but some sources use the non-standard unit of a 'bar'.
- $1 \text{ Pa} = 1 \text{ N.m}^{-2} = 1 \text{ kg.m}^{-1}.\text{s}^{-2} = 10^{-5} \text{ bar}$ or 0.01 mbar
- A 10 m high column of clean water at 4°C will produce 98 kPa (0.98 kN.m^{-2}) of pressure. A 100 mm high column of clean water at 4°C will produce 980 Pa (980 N.m^{-2}) of pressure.

Pressure and Force

Pressure is a measure of force over a given area. Normal atmospheric pressure is an **absolute pressure** measurement (with respect to a perfect vacuum) and shown as approximately 15 pounds per square inch (PSI) or 1 bar or 100 kPa or 100 kN.m^{-2} .

Normal gauges (such as the gauge in this equipment) show pressure with respect to atmosphere, so when the gauge shows zero pressure, its input is open to atmospheric pressure or at a pressure equivalent to atmospheric. The pressure shown by these gauges is termed '**gauge pressure**'.

With TecEquipment's Calibration of a Pressure Gauge, a known force is applied (the dead weight) to a plunger piston in a cylinder with a certain cross-sectional area.

The force (W) that the weight applies to the water in the cylinder is equal to the product of the mass (in kg) and the acceleration due to gravity.

Therefore:

$$W = mg \dots \dots \dots (1)$$

The pressure (p) caused by the force is therefore the force divided by the cross-sectional area of the cylinder (A), over which the force is applied:

$$p = \frac{W}{A} \dots \dots \dots (2)$$

The relative heights of the cylinder and gauge are similar, so there is very little 'pressure head' difference between them caused by different heights of water.

Therefore, the pressure is constant from the cylinder to the Bourdon gauge, so the gauge should give a direct reading of the pressure caused by the dead weight on the piston.

Calibration Constant

From Equations 1 and 2:

$$p = \frac{mg}{A}$$

Therefore, as the acceleration due to gravity (g) and area (A) are constant for the equipment, then the pressure (p) can be found by a simple calculation of:

$$p = m \times k$$

where $k = a$ constant found from g/A .

For example, for a piston area of 315 mm^2 (0.000315 m^2) and $g = 9.81 \text{ m.s}^{-2}$,

then $k = 31143$. Therefore:

$$\text{Pressure (in N.m}^{-2}\text{)} = \text{mass (in kg)} \times 31143$$

Or

$$\text{Pressure (in kN.m}^{-2}\text{)} = \text{mass (in kg)} \times 31.143$$

4. Procedure:

1. Create a blank table of results, similar to Table 1.
2. Note the cross-sectional area of the piston (indicated on the base of the equipment).

Table 1 Blank Results Table

Piston Area (A):							
Mass (m) (kg)	Force (W) (N)	Applied Pressure (p) kN.m^{-2}	Gauge Reading (kN.m^{-2})			Average Error (kN.m^{-2})	Error (% of full scale)
			Increasing	Decreasing	Average		

3. If fitted, carefully lift the piston from the cylinder and check that the gauge reads zero pressure. The gauge may need to be gently 'tapped' to make the indicator settle down to zero.

4. Carefully insert the piston with its loading platform. From the information on the equipment, note the mass of the piston (plunger) and platform, and write this in the first line of the results table. Note the gauge reading in the 'increasing' column of the results table.
5. Add the weights to the loading platform of the piston in at least 8 steps up to an indicated reading of around 170 kN.m^{-2} or a maximum applied mass of around 6 kg including the mass of the piston.
6. At each step, gently rotate the piston to help prevent the piston sticking and record the gauge reading in the *increasing* column.
7. Reverse the procedure, reducing the weights and recording the gauge readings as the pressure decreases.

5. Calculation:

1. Using equation 1, multiply the mass of the weight by the acceleration due to gravity to find the force (W) applied to the piston. Using equation 2, divide the force by the piston area to find the applied pressure.
2. Alternatively, find the applied pressure (in kN.m^{-2}) by multiplying the mass (in kg) by the calibration constant shown on the equipment.
3. Find the average pressure from the increasing and decreasing pressures. Subtract the applied pressure from the average pressure to find the average errors. Now divide by the full scale reading of the gauge and multiply by 100 to convert this into percentage of full scale.
4. Plot a chart of the increasing and decreasing gauge readings (vertical axis) against the applied pressure to give a visual indication of any hysteresis in the gauge.
5. Now plot a chart of the average error (vertical axis) against applied pressure to give a visual indication of the reading error across the pressure range.

6. References:

Kajikawa, H., & Kobata, T. (2016). Pressure gauge calibration applying 0-A-0 pressurization to reference gauge. *Acta Imeko*, 5(1), 59-63.

Sinha, M., Saini, S., Gupta, P., Gulati, N. S., Das, A., Kumar, A., ... & Shekhar, C. (2018). Current status and way forward for National Accreditation Board for testing and calibration laboratories accreditation of laboratories in government organizations. *Indian Journal of Pathology and Microbiology*, 61(3), 461.

Pressure gauge calibrator Data Sheet

Piston Area (A):							
Mass (m) (kg)	Force (W) (N)	Applied Pressure (p) kN.m^{-2}	Gauge Reading (kN.m^{-2})			Average Error (kN.m^{-2})	Error (% of full scale)
			Increasing	Decreasing	Average		

Instructor sign:
Date: